



figure

215

ends
formflange
straight

STOP VALVE



body material	nominal pressure	nominal diameter	max temperature
A grey cast iron	A 6 bar C 16 bar	DN 15-300	300°C
C nodular cast iron	C 16 bar D 25 bar	DN 15-200	350°C
E bronze	C 16 bar	DN 15-200	225°C
F cast steel	E 40 bar	DN 15-150	400°C



correspond to the pressure equipment directive 97/23/EC
marking CE for DN≥32

FEATURES

- high tightness (leakproofness class - A acc. EN -12266 - 1)
- compact settlement
- environment-friendly
- tests acc. EN - 12266 - 1
- flanges drilled according to EN 1092-2 for body material A, C, E
- flanges drilled according to EN 1092-1 for body material F
- face-to-face dimension according to EN 558-1 series 1

APPLICATION

- hot cold and cooling water plants
- steam plants
- industrial technologies
- heat engineering
- power engineering

Data given can be changed without notice.

Edition 11/2010



figure

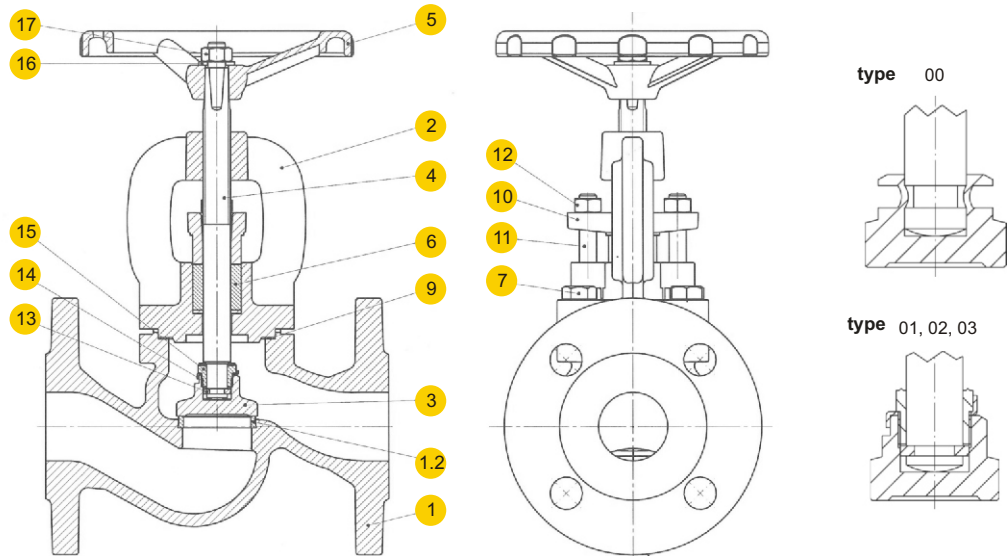
215

ends
form

flange
straight

MATERIALS

STOP VALVE



body material		A				C			E
type		00	01;04;71;91	02;05;72;92	03;13	01;04;71;91	02;05;72;92	03;13	03;23;73;93
1	body	EN – GJL-250 JL1040				EN – GJS-400 – 18-LT JS1025			CuSn5Zn5Pb5-C CC491K
1.2	seat ring	X12Cr13 1.4006		CuSn10 – C CC480K		X12Cr13 1.4006	CuSn10 – C CC480K		CuSn5Zn5Pb5-C CC491K
2	bonnet	EN-GJL-250 JL 1040				EN – GJS-400 – 18-LT JS1025			CuSn5Zn5Pb5-C CC491K
3	disc	X20Cr13 1.4021		CuSn10 – C CC480K		X20Cr13 1.4021	CuSn10 – C CC480K		CuSn5Zn5Pb5-C CC491K
4	stem	X20Cr13 1.4021		CuZn40Mn1,5	CuSn10 – C CC480K	X20Cr13 1.4021	CuZn40Mn1,5	CuSn10 – C CC480K	CuZn35Ni
5	hand-wheel	EN-GJS500-7 JS1050							
6	gland packing	graphite							
7	hexagon bolt	8.8				A2-70	8.8		A2-70
9	gasket	graphite+ NiCr							
10	gland	EN – GJL250 JL1040				EN – GJS400 – 18-LT JS1025			CuSn5Zn5Pb5-C CC491K
11	T-bolt	5.8 + zinc galvanized							A2-70
12	nut	8 + zinc galvanized							A2-70
13	ring	-----	X20Cr13 1.4021	CuSn10 – C CC480K		X20Cr13 1.4021	CuSn10 – C CC480K		CuSn5Zn5Pb5-C CC491K
14	washer	-----	X6CrNiTi18-10 1.4541	CuSn6		X6CrNiTi18-10 1.4541	CuSn6		CuSn6
15	screw	-----	X20Cr13 1.4021	CuSn10 – C CC480K		X20Cr13 1.4021	CuSn10 – C CC480K		CuSn5Zn5Pb5-C CC491K
16	washer	carbon steel + zinc galvanised							X5CrNi18-10 1.4301
17	nut	8 + zinc galvanised							A2-70
max. temperature		300°C	300°C	225°C		350°C	225°C	225°C	200°C

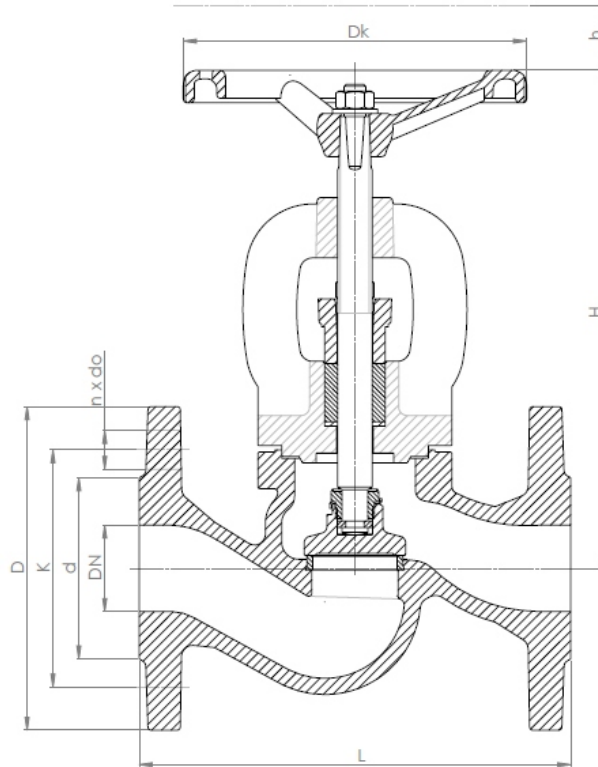
Data given can be changed without notice.

Edition 11/2010



figure **215**
ends form flange straight

DIMENSIONS **STOP VALVE**



DN	PN 6				PN 16				PN 25				PN 6, 16, 25					
	D	d	K	n x d	D	d	K	n x d	D	d	K	n x d	Dk	h	L	H		Kv _s
mm																	kg	m ³ /h
15	80	38	55	4x11	95	46	65	4x14	95	46	65	4x14	100	5	130	167	3,3	5,9
20	90	48	65	4x11	105	56	75	4x14	105	56	75	4x14	100	5,5	150	167	3,9	7,4
25	100	58	75	4x11	115	65	85	4x14	115	65	85	4x14	120	7	160	175	5,0	13,0
32	120	69	90	4x14	140	76	100	4x19	140	76	100	4x19	120	14	180	186	6,6	18,0
40	130	78	100	4x14	150	84	110	4x19	150	84	110	4x19	160	20	200	235	8,4	30,0
50	140	88	110	4x14	165	99	125	4x19	165	99	125	4x19	160	25	230	248	12,0	41,0
65	160	108	130	4x14	185	118	145	4x19	185	118	145	8x19	180	35	290	260	17,3	79,0
80	190	124	150	4x19	200	132	160	8x19	200	132	160	8x19	200	41	310	291	22,7	115
100	210	144	170	4x19	220	156	180	8x19	235	156	190	8x23	250	31	350	338	35,8	181
125	240	174	200	8x19	250	184	210	8x19	270	184	220	8x28	250	48	400	384	52,8	225
150	265	199	225	8x19	285	211	240	8x23	300	211	250	8x28	320	54	480	429	74,2	364
200	320	254	280	8x19	340	266	295	12x23	360	274	310	12x28	360	77	600	529	126	690
250	-	-	-	-	405	319	355	12x28	-	-	-	-	360	120	730	638	200	1010
300	-	-	-	-	460	370	410	12x28	-	-	-	-	500	120	850	710	315	1460

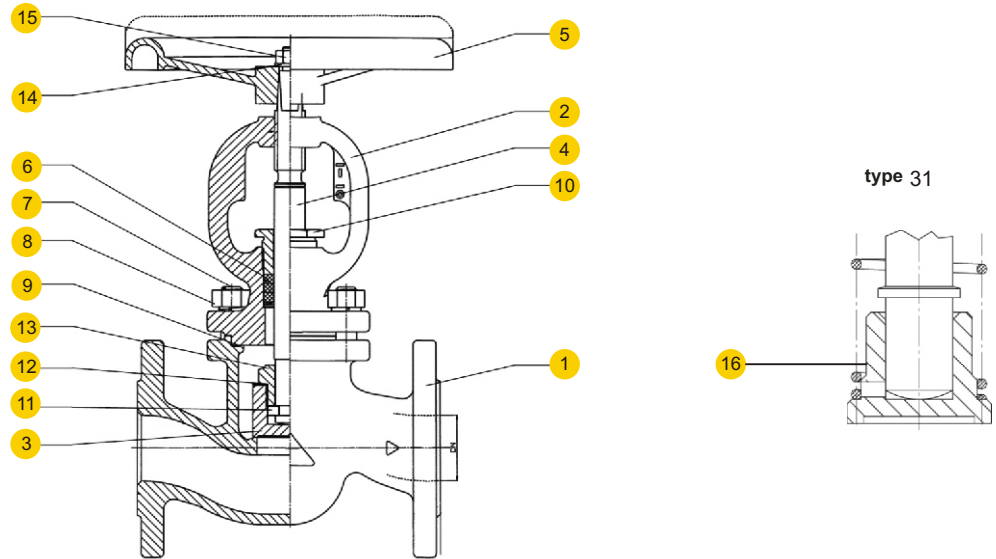
Data given can be changed without notice.

Edition 11/2010



figure	215
ends form	flange straight

MATERIALS



body material		F	
type		01,71	31
1	body	GP240GH+N 1.0619	
1.2	seat ring	X20Cr13 1.4006	
2	bonnet	GP240GH+N 1.0619	
3	disc	X20Cr13 1.4021	
4	stem	X20Cr13 1.4021	
5	hand-wheel	EN-GJS-400-18-LT JS 1025	
6	gland packing	all- graphite	
7	stud bolt	42CrMo5 1.7233	
8	nut	C35 1.1181	
9	gasket	graphite+ NiCr	
10	gland	11SMnPb30 1.0718	
11	ring	X20Cr13 1.4021	-----
12	washer	X6CrNiTi18-10 1.4541	-----
13	screw	X20Cr13 1.4021	-----
14	washer	carbon steel + zinc galvanised	
15	nut	carbon steel + zinc galvanised	
16	spring	-----	X17CrNi16-2 1.4057
max. temperature		400°C	

Data given can be changed without notice.

Edition 11/2010



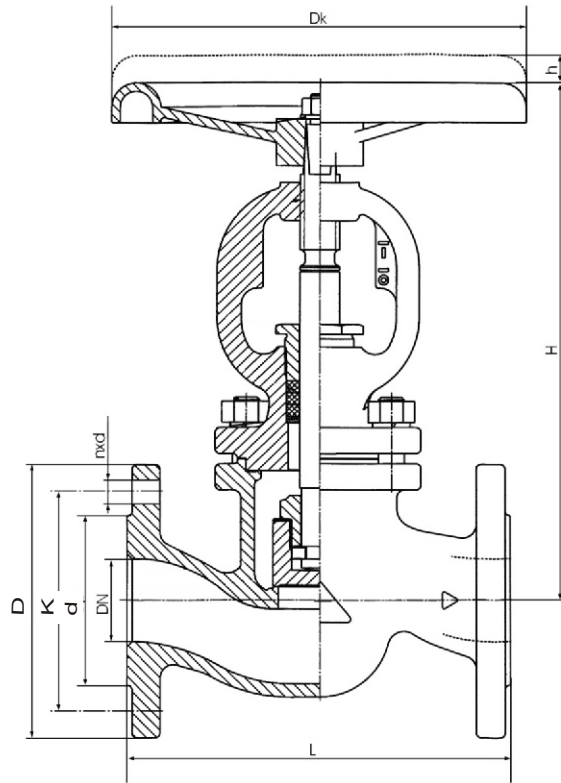
figure

215

ends
form

flange
straight

DIMENSIONS



DN	PN 40									K v _s	
	D	d	K	n x d	h	H	L	Dk			
mm										m ³ /h	kg
15	95	45	65	4×14	6	189	130	120	4,3	4,3	
20	105	58	75	4×14	6	189	150	120	7,0	5,1	
25	115	68	85	4×14	6	189	160	120	11,0	5,8	
32	140	78	100	4×18	10	220	180	160	17,5	9,5	
40	150	88	110	4×18	10	220	200	160	27,0	9,8	
50	165	102	125	4×18	16,5	295	230	195	47,0	17,5	
65	185	122	145	8×18	16,5	295	290	195	68,0	20,5	
80	200	138	160	8×18	25	368	310	280	116,0	34	
100	235	162	190	8×22	25	368	350	280	162,0	44	
125	270	188	220	8×26	40	523	400	350	250,0	77	
150	300	218	250	8×26	40	523	480	350	364,0	113	
200	375	285	320	12×30	92	576	600	400	550,0	180	

Data given can be changed without notice.

Edition 11/2010

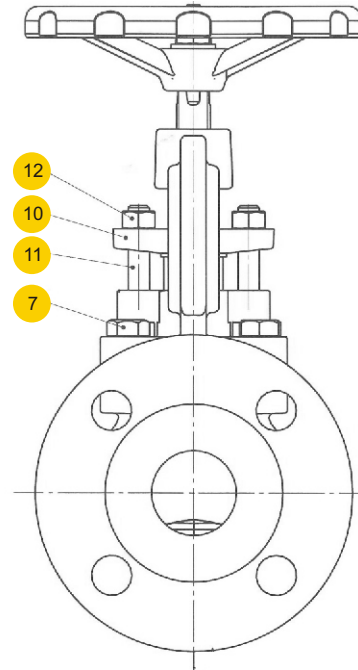
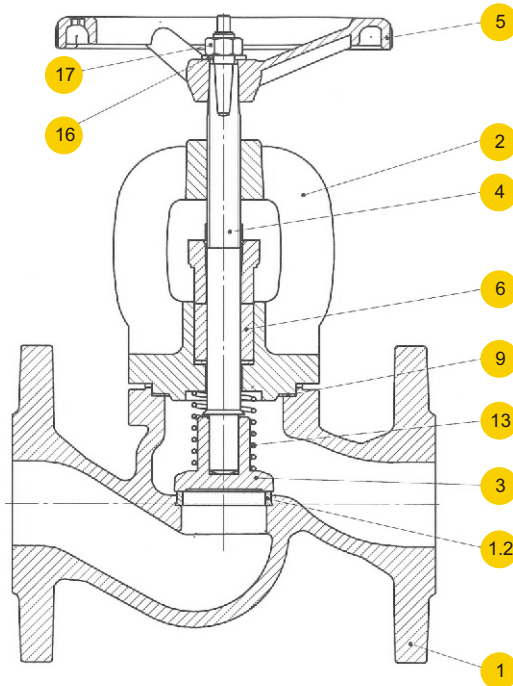


figure **215**

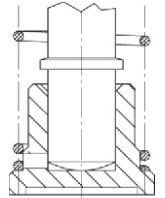
ends form flange straight

MATERIALS

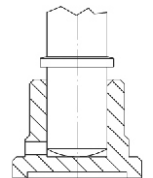
SCREW-DOWN STOP AND CHECK VALVE



type 31, 32, 33



type 41, 42, 43



	body material	A			C			E
	type	31;41*	32;42*	33;43*	31;41*	32;42*	33;43*	31;41*
1	body	EN-GJL250 JL1040			EN – GJS400 – 18-LT JS1025			CuSn5Zn5Pb5-C CC491K
1.2	seat ring	X12Cr13 1.4006	CuSn10 – C CC480K		X12Cr13 1.4006	CuSn10 – C CC480K		CuSn5Zn5Pb5-C CC491K
2	bonnet	EN-GJL250 JL1040			EN – GJS400 – 18-LT JS1025			CuSn5Zn5Pb5-C CC491K
3	disc	X20Cr13 1.4021	CuSn10 – C CC480K		X20Cr13 1.4021	CuSn10 – C CC480K		CuSn5Zn5Pb5-C CC491K
4	stem	X20Cr13 1.4021	CuZn40Mn1,5	CuSn10 – C	X20Cr13 1.4021	CuZn40Mn1,5	CuSn10 – C	CuZn35Ni
5	hand-wheel	EN-GJS500-7 JS1050						
6	gland packing	all- graphite						
7	hexagon bolt	8.8			A2-70	8,8		A2-70
9	gasket	graphite+ NiCr						
10	gland	EN – GJL250 JL1040			EN – GJS400 – 18-LT JS1025			CuSn5Zn5Pb5-C CC491K
11	T-bolt	5.8 + zinc galvanized						A2-70
12	nut	8 + zinc galvanized						A2-70
13	spring	X17CrNi16-2	X17CrNi16-2 1.4057	X17CrNi16-2	X17CrNi16-2 1.4057			CuSn6
14	washer	carbon steel + zinc galvanized						X5CrNi18-10 1.4301
15	nut	8 zinc galvanized						A2-70
	max. temperature	350°C	225°C	225°C	350°C	225°C	225°C	200°C

*bez sprężyny / without spring

Data given can be changed without notice.

Edition 11/2010



figure

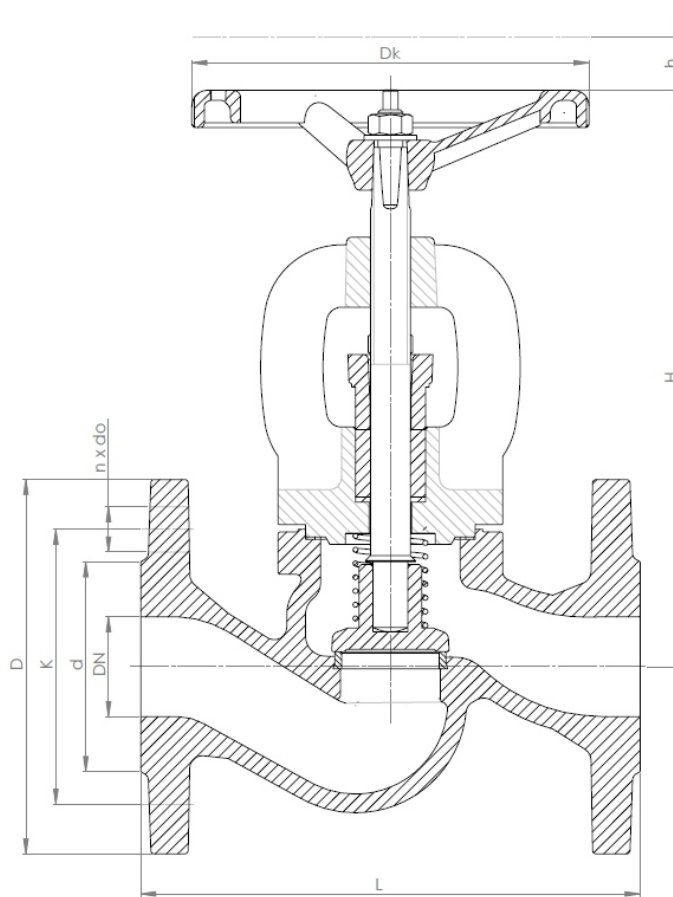
215

ends
form

flange
straight

DIMENSIONS

SCREW-DOWN STOP AND CHECK VALVE



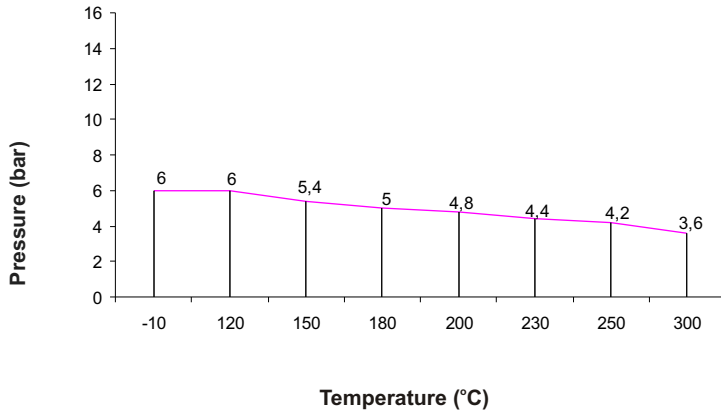
DN	PN 6				PN 16				PN 25				PN 6,16,25				Kv _s		
	D	d	K	n x d	D	d	K	n x d	D	d	K	n x d	Dk	h	L	H		kg	m ³ /h
mm																			
15	80	38	55	4×11	95	46	65	4 x 14	95	46	65	4 x 14	100	5	130	167	3,3	5,9	
20	90	48	65	4×11	105	56	75	4 x 14	105	56	75	4 x 14	100	5,5	150	167	3,9	7,4	
25	100	58	75	4×11	115	65	85	4 x 14	115	65	85	4 x 14	120	7	160	175	5	13	
32	120	69	90	4 x 14	140	76	100	4 x 19	140	76	100	4 x 19	120	14	180	186	6,6	18	
40	130	78	100	4 x 14	150	84	110	4 x 19	150	84	110	4 x 19	160	20	200	235	8,4	30	
50	140	88	110	4 x 14	165	99	125	4 x 19	165	99	125	4 x 19	160	25	230	248	12	41	
65	160	108	130	4 x 14	185	118	145	4 x 19	185	118	145	8 x 19	180	35	290	260	17,3	79	
80	190	124	150	4 x 19	200	132	160	8 x 19	200	132	160	8x 19	200	41	310	291	22,7	115	
100	210	144	170	4 x 19	220	156	180	8 x 19	235	156	190	8 x 19	250	31	350	338	35,8	181	
125	240	174	200	8 x 19	250	184	210	8 x 19	270	184	220	8 x 23	250	48	400	384	52,8	225	
150	265	199	225	8 x 19	285	211	240	8 x 23	300	211	250	8 x 28	320	54	480	429	74,2	364	
200	320	254	280	8 x 19	340	266	295	12 x 23	360	274	310	12 x 28	360	77	600	529	126	690	
250	-	-	-	-	405	355	355	12 x 28	-	-	-	-	360	120	730	638	200	1010	
300	-	-	-	-	460	370	410	12 x 28	-	-	-	-	500	120	850	710	315	1460	

Data given can be changed without notice.

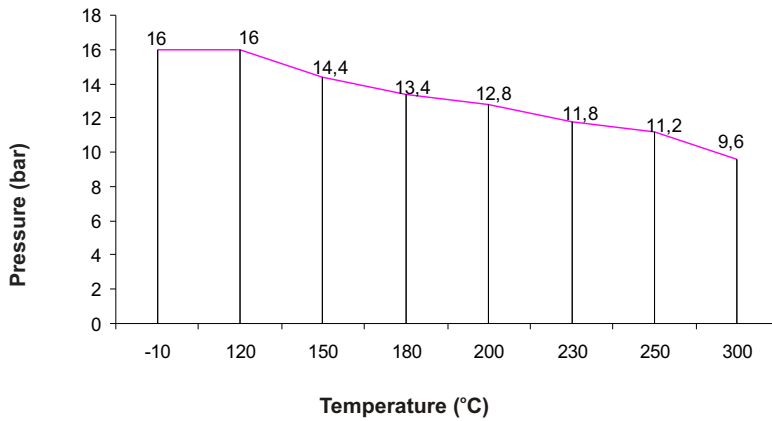
Edition 11/2010



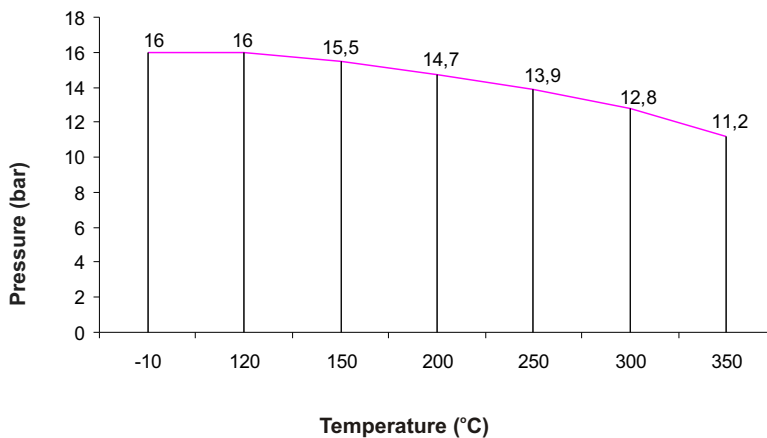
PRESSURE-TEMPERATURE RATINGS



Allowed working conditions range
PN 6 EN-GJL-250



Allowed working conditions range
PN 16 EN-GJL-250

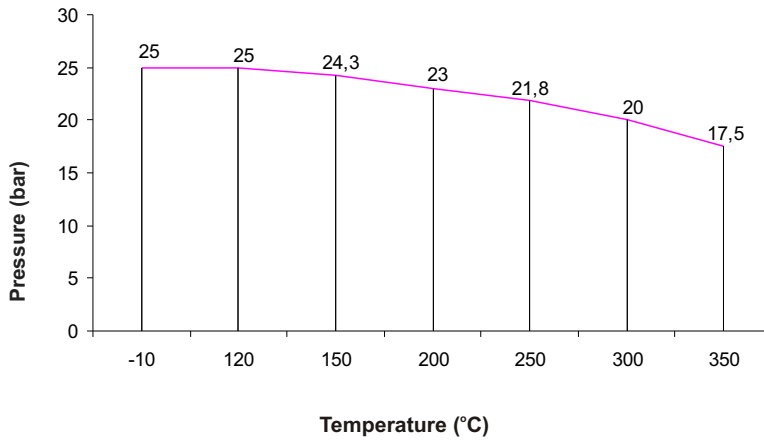


Allowed working conditions range
PN 16 EN-GJS-400-18-LT

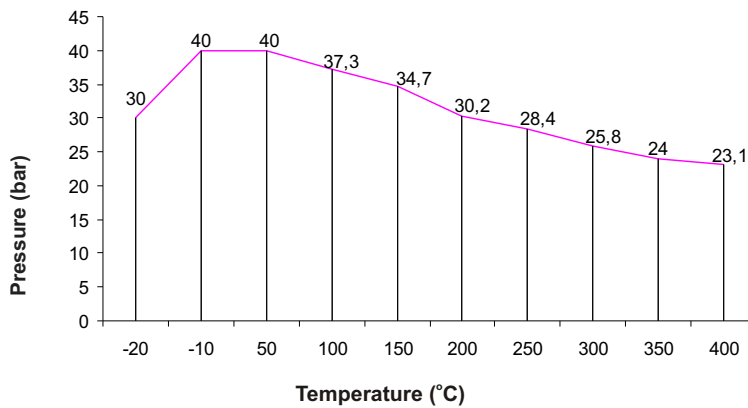


figure	215
ends form	flange straight

PRESSURE-TEMPERATURE RATINGS



Allowed working conditions range
PN 25 EN-GJS-400-18-LT



Allowed working conditions range
PN 40 GP24GH 1.0619



figure	215
ends form	flange straight

TYPES

figure	body material	nominal diameter DN	nominal pressure PN	type
215	A grey cast iron EN-GJL-250	15-50 mm	A 6bar	00 • stem and disc connection - fixed - rolled • stem, disc and seat ring - stainless steel
		15-150 mm	A 6bar	01 • stem and disc connection - nut • stem, disc and seat ring - stainless steel
		200-300 mm	A 6bar	04 • stem and disc connection - nut • stem, disc and seat ring - stainless steel • balancing disc
		15-150 mm	A 6bar	02 • stem and disc connection nut • stem - brass, disc and seat ring - bronze
		200-300 mm	A 6bar	05 • stem and disc connection - nut • stem - brass, disc and seat ring - bronze • balancing disc
		15-150 mm	A 6bar	03 • stem and disc connection nut • stem, disc and seat ring - bronze
		200-300 mm	A 6bar	13 • stem and disc connection - nut • stem, disc and seat ring - bronze • balancing disc
		15-300 mm	A 6bar	31 • loose disc with spring • stem, disc and seat ring - stainless steel
		15-300 mm	A 6bar	41 • loose disc without spring • stem, disc and seat ring - stainless steel
		15-300 mm	A 6bar	32 • loose disc with spring • stem - brass, disc and seat ring - bronze
		15-300 mm	A 6bar	42 • loose disc without spring • stem - brass, disc and seat ring - bronze
		15-300 mm	A 6bar	33 • loose disc with spring • stem, disc and seat ring - bronze
		15-300 mm	A 6bar	43 • loose disc without spring • stem, disc and seat ring - bronze
		15-300 mm	A 6bar	71 • stem and disc connection - nut • stem, throttling disc and seat ring - stainless steel • throttling disc • without position indicator
		15-300 mm	A 6bar	91 • stem and disc connection - nut • stem, throttling disc and seat ring - stainless steel • throttling disc • with position indicator
		15-200 mm	A 6bar	72 • stem and disc connection - nut • stem - brass, throttling disc and seat ring - bronze • throttling disc • without position indicator
		15-200 mm	A 6bar	92 • stem and disc connection - nut • stem - brass, throttling disc and seat ring - bronze • throttling disc • with position indicator

Data given can be changed without notice.

Edition 11/2010



figure	215
ends form	flange straight

TYPES

figure	body material	nominal diameter DN	nominal pressure PN	type
215	A grey cast iron EN-GJL-250	15-50 mm	C 16bar	00 * stem and disc connection - fixed - rolled * stem, disc and seat ring - stainless steel
		15-150 mm	C 16bar	01 * stem and disc connection - nut * stem, disc and seat ring - stainless steel
		200-300 mm	C 16bar	04 * stem and disc connection - nut * stem, disc and seat ring - stainless steel * balancing disc
		15-150 mm	C 16bar	02 * stem and disc connection nut * stem - brass, disc and seat ring - bronze
		200-300 mm	C 16bar	05 * stem and disc connection - nut * stem- brass, disc and seat ring - bronze * balancing disc
		15-150 mm	C 16bar	03 * stem and disc connection nut * stem, disc and seat ring - bronze
		200-300 mm	C 16bar	13 * stem and disc connection - nut * stem, disc and seat ring - bronze * balancing disc
		15-300 mm	C 16bar	31 * loose disc with spring * stem, disc and seat ring - stainless steel
		15-300 mm	C 16bar	41 * loose disc without spring * stem, disc and seat ring - stainless steel
		15-300 mm	C 16bar	32 * loose disc with spring * stem - brass, disc and seat ring - bronze
		15-300 mm	C 16bar	42 * loose disc without spring * stem - brass, disc and seat ring - bronze
		15-300 mm	C 16bar	33 * loose disc with spring * stem, disc and seat ring - bronze
		15-300 mm	C 16bar	43 * loose disc without spring * stem, disc and seat ring - bronze
		15-300 mm	C 16bar	71 * stem and disc connection - nut * stem, throttling disc and seat ring - stainless steel * throttling disc * without position indicator
		15-300 mm	C 16bar	91 * stem and disc connection - nut * stem, throttling disc and seat ring - stainless steel * throttling disc * with position indicator
		15-200 mm	C 16bar	72 * stem and disc connection - nut * stem- brass, throttling disc and seat ring - bronze * throttling disc * without position indicator
		15-200 mm	C 16bar	92 * stem and disc connection - nut * stem - brass, throttling disc and seat ring - bronze * throttling disc * with position indicator

Data given can be changed without notice.

Edition 11/2010



figure	215
ends form	flange straight

TYPES

figure	body material	nominal diameter DN	nominal pressure PN	type
215	C nodular cast iron EN-GJS-400-18-LT	15-150 mm	C 16bar	01 * stem and disc connection - nut * stem, disc and seat ring - stainless steel
		200 mm	C 16bar	04 * stem and disc connection - nut * stem, disc and seat ring - stainless steel * balancing disc
		15-150 mm	C 16bar	02 * stem and disc connection nut * stem - brass, disc and seat ring - bronze
		200 mm	C 16bar	05 * stem and disc connection - nut * stem- brass, disc and seat ring - bronze * balancing disc
		15-150 mm	C 16bar	03 * stem and disc connection nut * stem, disc and seat ring - bronze
		200 mm	C 16bar	13 * stem and disc connection - nut * stem, disc and seat ring - bronze * balancing disc
		15-200 mm	C 16bar	31 * loose disc with spring * stem, disc and seat ring - stainless steel
		15-200 mm	C 16bar	41 * loose disc without spring * stem, disc and seat ring - stainless steel
		15-200 mm	C 16bar	32 * loose disc with spring * stem - brass, disc and seat ring - bronze
		15-200 mm	C 16bar	42 * loose disc without spring * stem - brass, disc and seat ring - bronze
		15-200 mm	C 16bar	33 * loose disc with spring * stem, disc and seat ring - bronze
		15-200 mm	C 16bar	43 * loose disc without spring * stem, disc and seat ring - bronze
		15-200 mm	C 16bar	71 * stem and disc connection - nut * stem, throttling disc and seat ring - stainless steel * throttling disc * without position indicator
		15-200 mm	C 16bar	91 * stem and disc connection - nut * stem, throttling disc and seat ring - stainless steel * throttling disc * with position indicator
		15-200 mm	C 16bar	72 * stem and disc connection - nut * stem- brass, throttling disc and seat ring - bronze * throttling disc * without position indicator
		15-200 mm	C 16bar	92 * stem and disc connection - nut * stem - brass, throttling disc and seat ring - bronze * throttling disc * with position indicator

Data given can be changed without notice.

Edition 11/2010



figure	215
ends form	flange straight

TYPES

figure	body material	nominal diameter DN	nominal pressure PN	type
215	C nodular cast iron EN-GJS-400-18-LT	15-150 mm	D 25bar	01 * stem and disc connection - nut * stem, disc and seat ring - stainless steel
		200 mm	D 25bar	04 * stem and disc connection - nut * stem, disc and seat ring - stainless steel * balancing disc
		15-150 mm	D 25bar	02 * stem and disc connection nut * stem - brass, disc and seat ring - bronze
		200 mm	D 25bar	05 * stem and disc connection - nut * stem - brass, disc and seat ring - bronze * balancing disc
		15-150 mm	D 25bar	03 * stem and disc connection nut * stem, disc and seat ring - bronze
		200 mm	D 25bar	13 * stem and disc connection - nut * stem, disc and seat ring - bronze * balancing disc
		15-200 mm	D 25bar	31 * loose disc with spring * stem, disc and seat ring - stainless steel
		15-200 mm	D 25bar	41 * loose disc without spring * stem, disc and seat ring - stainless steel
		15-200 mm	D 25bar	32 * loose disc with spring * stem - brass, disc and seat ring - bronze
		15-200 mm	D 25bar	42 * loose disc without spring * stem - brass, disc and seat ring - bronze
		15-200 mm	D 25bar	33 * loose disc with spring * stem, disc and seat ring - bronze
		15-200 mm	D 25bar	43 * loose disc without spring * stem, disc and seat ring - bronze
		15-200 mm	D 25bar	71 * stem and disc connection - nut * stem, throttling disc and seat ring - stainless steel * throttling disc * without position indicator
		15-200 mm	D 25bar	91 * stem and disc connection - nut * stem, throttling disc and seat ring - stainless steel * throttling disc * with position indicator

Data given can be changed without notice.

Edition 11/2010



figure	215
ends form	flange straight

TYPES

figure	body material	nominal diameter DN	nominal pressure PN	type
215	E bronze CuZn5Zn5Pb5-C	15-300 mm	C 16bar	03 • stem and disc connection nut • stem, disc and seat ring - bronze
		15-300 mm	C 16bar	33 • loose disc with spring • stem, disc and seat ring - bronze
		15-300 mm	C 16bar	43 • loose disc without spring • stem, disc and seat ring - bronze
		15-300 mm	C 16bar	23 • stem and disc connection - nut • with position indicator • stem, disc and seat ring - bronze
		15-300 mm	C 16bar	53 • loose disc with spring • with position indicator • stem, disc and seat ring - bronze
		15-300 mm	C 16bar	63 • loose disc without spring • with position indicator • stem, disc and seat ring - bronze
		15-150 mm	C 16bar	73 • stem and disc connection - nut • throttling disc - bronze • without position indicator
		15-150 mm	C 16bar	93 • stem and disc connection - nut • throttling disc - bronze • with position indicator
	F stalowo cast steel GP240GH 1.0619	15-150 mm	E 40bar	01 • stem and disc connection - nut • stem, disc and seat ring - stainless steel
		200 mm	E 40bar	00 • stem and disc connection balls • stem, throttling disc and seat ring - stainless steel
		15-200 mm	E 40bar	31 • loose disc with spring • stem, disc and seat ring - stainless steel
		15-200 mm	E 40bar	71 • stem and disc connection - nut • stem, disc and seat ring - stainless steel • throttling disc

Data given can be changed without notice.

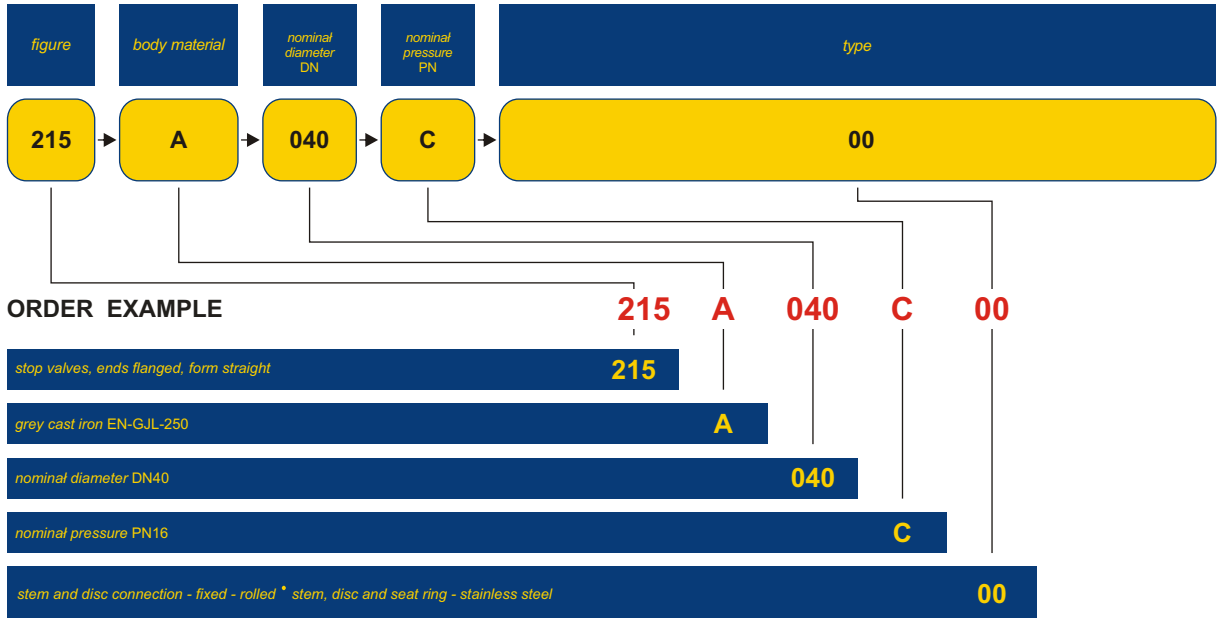
Edition 11/2010



figure	215
ends form	flange straight

ORDERING

To place an order please use our product number (index)



BELLOW VALVE zBEL



Body material	Nominal pressure	Nominal diameter	Max. temperature
A Grey cast iron	C 16 bar	DN 15-250	300°C
C Nodular cast iron	C 16 bar D 25 bar	DN 15-200	350°C
F Cast steel	E 40 bar	DN 15-200	450°C
I Cast stainless steel	E 40 bar	DN 15-200	400°C



correspond to the pressure equipment directive 2014/68/UE marking CE for DN≥32

FEATURES

- high tightness (leakproofness class - A acc. EN -12266 - 1)
- compact settlement
- environment-friendly
- tests acc. EN - 12266 - 1
- flanges drilled according to EN 1092-2 for body material A, C, E
- flanges drilled according to EN 1092-1 for body material F, I
- face-to-face dimension according to EN 558 series 1
- non-rising handwheel
- ISO 15848-1 Class AH – TA-LUFT
- double wall bellows seal

APPLICATION *

* not all of the applications are suitable for all of the executions
On the website www.zetkama.com.pl is a Chemical Resistance List, which specifies the parameters of work for a given medium.

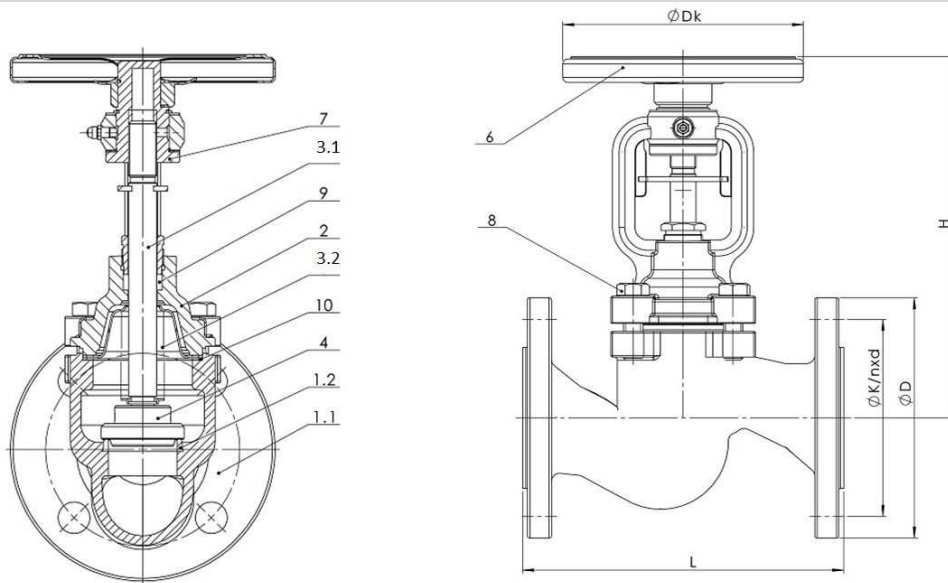
industries							
	INDUSTRY	SHIPBUILDING INDUSTRY	HEATING	REFRIGERATION AND AIR CONDITIONING	CHEMICAL INDUSTRY		
media							
	GLYCOL	INDUSTRIAL WATER	DIATHERMIC OIL	STEAM	COMPRESSED AIR	NEUTRAL FLUIDS	HYDROGEN

Data given can be changed without notice.

Edition 10/2023

FIG.234

MATERIALS, DIMENSIONS



		Body material	A	C
Spare parts	Type	01; 04; 71	01; 04; 71	
1.1	Body	EN – GJL-250 5.1301 (ex. JL1040)	EN – GJS-400 – 18-LT 5.3103 (ex.JS1025)	
1.2	Seat ring	X12Cr13 1.4021		
2	Bonnet	EN – GJS-400 – 18-LT 5.3103 (ex.JS1025)		
X	3	Sub-assembly of stem and bellow		
	3.1	Stem	X20Cr13 1.4021	
	3.2	Bellow	X6CrNiMoTi-17-12-2	
	4	Disc	X20Cr13+QT 1.4021	
	6	Handwheel	Steel	
	7	Sleeve	11SMnPb30	
	8	Hexagon bolt	5.6	A2-70
	9	Gland packing	Graphite	
X	10	Bonnet gasket	Graphite+ CrNiSt	
Max. temperature		300°C		350°C

DN		15	20	25	32	40	50	65	80	100	125	150	200	250
L (mm)		130	150	160	180	200	230	290	310	350	400	480	600	730
Dk (mm)		125	125	125	125	150	150	175	200	250	300	400	500	600
H		178	178	193	201	224	228	270	295	325	380	427	569	645
Kvs (m³/h)	01;04	5,9	7,4	13	18	30	41	79	115	181	225	364	725	-----
	71	3,2	3,9	4,85	6,5	9,0	11	15,8	24,3	35	49	76	130,5	210
Weight (kg)	01;04	3,2	3,9	4,85	6,5	9,0	11	15,8	24,3	35	49	76	130,5	210
	71	3,2	3,9	5,0	6,7	9,3	11,5	16,3	21,4	36	51,5	78	130,5	-----

Data given can be changed without notice.

Edition 10/2023

ZETKAMA Sp. z o.o.
Ul. 3 Maja 12
PL 57-410 Ścinawka Średnia

Tel. +48 74 8652 193
Tel. +48 74 8652 111
Fax +48 74 8652 199

E-mail export@zetskama.com.pl
www.zetskama.com

KV [m³/h] FIG. 234-71 (A,C)

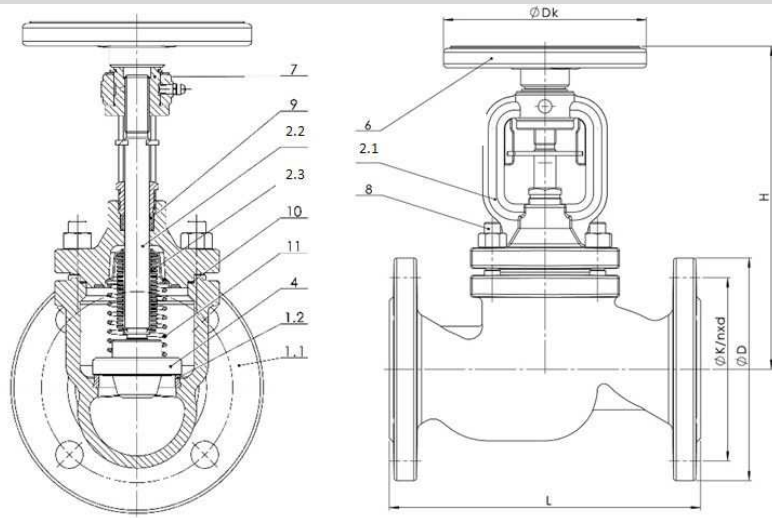
Turn	DN 15	DN 20	DN 25	DN 32	DN 40	DN 50	DN 65	DN 80	DN 100	DN 125	DN 150	DN 200
0,5	0,86	1,1	1,35	1,72	4,1	2,94	4,5	-	-	-	-	-
1	1,32	178	1,87	2,34	5,64	3,61	5,5	8,1	14,3	23	28	110
1,5	1,91	2,82	2,78	3,21	7,33	4,81	7,0	-	15,2	29,8	-	-
2	2,78	4,16	3,82	4,83	9,16	6,5	8,8	12,8	25,3	37	-	190
2,15	3,02	-	-	-	-	-	-	-	-	-	-	-
2,5		5,5	5,2	6,2	11,2	8,5	10,7	-	34,4	-	-	-
2,7		6,1	-	-	-	-	-	-	-	-	-	-
3			6,7	7,8	13,6	10,7	13,3	17,2	45,1	54,9	56	257
3,5			8	9,6	15,8	13,5	16,2	-	55	-	-	-
3,7			8,6	-	-	-	-	-	-	-	-	-
4				11,4	18,6	16,3	19,6	24,9	67	79,5	80	312
4,5				13,1	20,9	19,2	23,4	-	78,9	95,8	-	-
4,85				14	-	-	-	-	-	-	-	-
5					23,2	22,8	27,1	31,4	94,6	109	116	369
5,5						26,3	30,7	-	-	-	-	-
6						30,1	35,6	42,1	121,6	144,1	145	418
6,25						31,8	-	-	127,1	-	-	-
7							45,3	50,4		176	182	468
7,9							-	-		201,5	-	-
8							54,6	60,4			222	516
8,25							56,83	-			-	-
8,33								-			-	532
9								70,3			258	
9,4								-			273	
10								78,5				

Data given can be changed without notice.

Edition 10/2023

FIG.234

MATERIALS, DIMENSIONS



Spare parts	Type	Body material			
		01	04	31	71
	1.1	GP240GH			
	1.2	G199 LSi			
X	2	Sub-assembly of bonnet, bellow and stem			
	2.2	GP240GH			
	2.2	X20Cr13 1.4021			
	2.3	X6CrNiMoTi17-12-2			
	4	Stop disc X20Cr13 +QT 1.4021	balancing disc X20Cr13 +QT 1.4021	SDNR X20Cr13 +QT 1.4021	throttling disc X20Cr13 +QT 1.4021
	6	Steel			
	7	11SMnPb30			
	8	25CrMo4			
	9	Graphite			
X	10	Graphite			
	11	-----	-----	X17CrNi16-2 1.4057	-----
Max. temperature		450°C			

DN	15	20	25	32	40	50	65	80	100	125	150	200
L (mm)	130	150	160	180	200	230	290	310	350	400	480	600
Dk (mm)	125	125	125	125	200	200	250	250	300	300	400	400
H (mm)	190	190	190	195	240	240	270	300	450	520	570	627
Kvs (m³/h)	6,0	8,7	15,5	25,3	28,8	46,5	76,4	113,2	180,2	238,7	358,2	552
Weight (kg)	4,3	5,1	6,0	7,6	11,5	13,7	20,1	27,5	44,0	65,5	110,0	172,5

Data given can be changed without notice.

Edition 10/2023

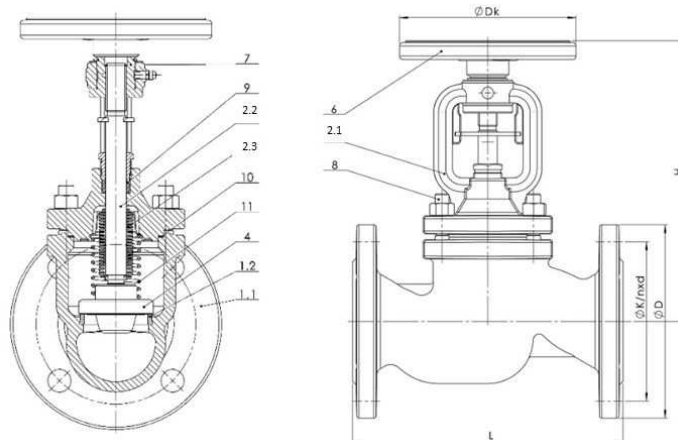
ZETKAMA Sp. z o.o.
Ul. 3 Maja 12
PL 57-410 Ścinawka Średnia

Tel. +48 74 8652 193
Tel. +48 74 8652 111
Fax +48 74 8652 199

E-mail export@zetskama.com.pl
www.zetskama.com

FIG.234

MATERIALS, DIMENSIONS



		Body material	I			
Spare parts		Type	01	04	31	71
	1.1	Body	G-X5CrNiMo19-11-2 1.4408			
	1.2	Seat	G 19 9 L Si			
X	2	Sub-assembly of bonnet, bellow and stem of bonnet				
	2.1	Bonnet	G-X5CrNiMo19-11-2 1.4408			
	2.2	Stem	X6CrNiMoTi17-12-2 1.4571			
	2.3	Bellow	X6CrNiMoTi17-12-2 1.4571			
	4	Disc	Stop disc X6CrNiMoTi17-12-2 1.4571	Balancing disc X6CrNiMoTi17-12-2 1.4571	SDNR X6CrNiMoTi17-12-2 1.4571	Throttling disc X20Cr13 +QT 1.4021
	6	Handwheel	Steel			
	7	sleeve	11SMnPb30			
	8	Bolt, nut	A4-70			
	9	Gland packing	Graphite			
X	10	Bonnet gasket	Graphite			
	11	Spring	----		X17CrNi16-2 1.4057	---
		Max. temperature	400°C			

DN	15	20	25	32	40	50	65	80	100	125	150	200
L (mm)	130	150	160	180	200	230	290	310	350	400	480	600
Dk (mm)	125	125	125	125	200	200	250	250	300	300	400	400
H (mm)	190	190	190	195	240	240	270	300	450	520	570	627
Kvs (m³/h)	6,0	8,7	15,5	25,3	28,8	46,5	76,4	113,2	180,2	238,7	358,2	552
Weight (kg)	3,8	4,9	5,7	7,4	10,7	13,1	19,5	25,7	43,9	64,8	95,0	152,0

Data given can be changed without notice.

Edition 10/2023

ZETKAMA Sp. z o.o.
Ul. 3 Maja 12
PL 57-410 Ścinawka Średnia

Tel. +48 74 8652 193
Tel. +48 74 8652 111
Fax +48 74 8652 199

E-mail export@zetskama.com.pl
www.zetskama.com

KV [m³/h] FIG. 234-71 (F, I)

Obroty kółka	DN 15	DN 20	DN 25	DN 32	DN 40	DN 50	DN 65	DN 80	DN 100	DN 125	DN 150	DN 200
0,5	0,34	1,05	1,46	1,77	4,1	3,7	5,3	5,2	10,6	15,7	11,1	48
1	0,83	2,03	1,83	2,38	5,9	4,5	5,6	6,9	16,6	22,6	36,5	70
1,5	1,95	3,07	2,98	3,66	7,9	5,5	6,0	8,4	24,9	28,7	48	85
2	2,87	4,55	4,3	5,1	9,6	7,6	7,8	10,0	36,3	37,1	56	96
2,5	3,7	5,8	6,0	6,9	11,5	9,8	9,9	12,4	50	50	64	106
3	4,3	6,5	7,5	9,0	13,9	11,9	12,7	14,7	65	66	72	117
3,5			8,9	10,7	16,0	14,9	15,7	17,5	82	86	80	127
4			10,3	12,7	18,9	18,0	19,2	20,8	100	105	92	138
4,5			11,0	13,7	21,6	22,8	22,7	24,3	117	128	107	161
5					24,4	26,5	26,4	28,1	133	152	133	181
5,5					27,0	30,1	30,9	32,4	146	174	164	225
6					29,5	33,6	35,7	37,2		195	199	263
6,5					31,4	37,4	41	43		212	235	321
7					32,5	40,0	46	49		225	269	367
7,5							52	55			301	419
8							57	62			329	460
8,5							62	68				493
9							67	75				515
9,5												532

Data given can be changed without notice.

Edition 10/2023

ZETKAMA Sp. z o.o.
 Ul. 3 Maja 12
 PL 57-410 Ścinawka Średnia

Tel. +48 74 8652 193
 Tel. +48 74 8652 111
 Fax +48 74 8652 199

E-mail export@zetkama.com.pl
 www.zetkama.com

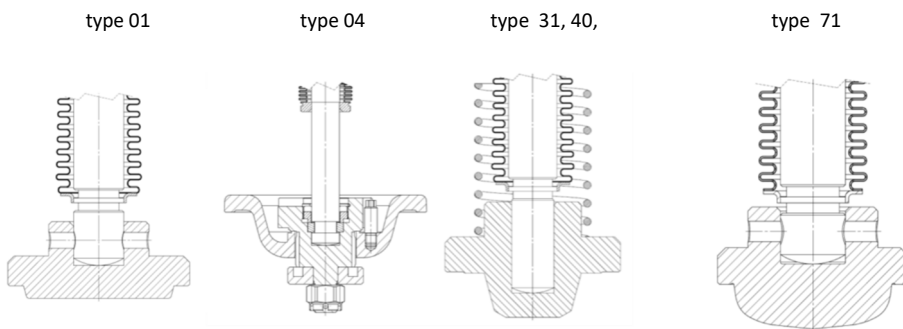
PRESSURE-TEMPERATURE RATINGS

PN		---	-10°±120°C	150°C	200°C	250°C	300°C	350°C	400°C	450°C		
EN-GJL-250	16	bar	---	16	14,4	12,8	11,2	9,6	---	---		
EN-GJS-400-18 LT	16		---	16	15,5	14,7	13,9	12,8	11,2	---		
	25		---	25	24,3	23	21,8	20	17,5	---		
Acc. EN 1092-1			-40°÷<-10°C	-10°±50°C	100°C	150°C	200°C	250°C	300°C	350°C	400°C	450°C
GP240GH	40	bar	30	40	37,1	35,2	33,3	30,4	27,6	25,7	23,8	13,1
Acc. EN 1092-1			---	-60°÷<-10°C	-10°C±100°C	150°C	200°C	250°C	300°C	350°C	400°C	450°C
G-X5CrNiMo19-11-2	40		---	40	40	36,3	33,7	31,8	29,7	28,5	27,4	---

FLANGE DIMENSIONS ACC. PN-EN 1092-1/-2

DN		15	20	25	32	40	50	65	80	100	125	150	200	250	300
PN16	D (mm)	95	105	115	140	150	165	185	200	220	250	285	340	405	----
	K (mm)	65	75	85	100	110	125	145	160	180	210	240	295	355	----
	nxd (mm)	4x14	4x14	4x14	4x19	4x19	4x19	4x19	8x19	8x19	8x19	8x23	12x23	12x28	----
PN25	D (mm)	95	105	115	140	150	165	185	200	235	270	300	360	----	----
	K (mm)	65	75	85	100	110	125	145	160	190	220	250	310	----	----
	nxd (mm)	4x14	4x14	4x14	4x19	4x19	4x19	8x19	8x19	8x23	8x28	8x28	12x28	----	----
PN40	D (mm)	95	105	115	140	150	165	185	200	235	270	300	375	----	----
	K (mm)	65	75	85	100	110	125	145	160	190	220	250	320	----	----
	nxd (mm)	4x14	4x14	4x14	4x18	4x18	4x18	8x18	8x18	8x22	8x26	8x26	12x30	----	----

DISC



Other type of valves on request:

- stellited seat
- hardened disc
- other

Data given can be changed without notice.

Edition 10/2023

TYPE

Figure	Body material	Nominal diameter	Nominal pressure	Type
234	A Grey cast iron EN-GJL-250	15-150 mm	C 16 bar	01 stem connected with bellow; stem, disc, bellow and seat ring - stainless steel
		200-250 mm	C 16 bar	04 stem connected with bellow; stem, balancing disc; bellow and seat ring - stainless steel
		15-200 mm	C 16 bar	71 stem connected with bellow; stem, throttling disc; bellow and seat ring - stainless steel
234	C Nodular cast iron EN-GJS-400-18-LT	15-150 mm	C 16 bar	01 stem connected with bellow; stem, disc, bellow and seat ring - stainless steel
		200 mm	C 16 bar	04 stem connected with bellow; stem, balancing disc; bellow and seat ring - stainless steel
		15-200 mm	C 16 bar	71 stem connected with bellow; stem, throttling disc; bellow and seat ring - stainless steel
		15-150 mm	D 25 bar	01 stem connected with bellow; stem, disc, bellow and seat ring - stainless steel
		200 mm	D 25 bar	04 stem connected with bellow; stem, balancing disc; bellow and seat ring - stainless steel
234	F cast steel GP240GH 1.0619	15-100 mm	E 40 bar	01 stem connected with bellow; stem, disc, bellow and seat ring - stainless steel
		125-200 mm	E 40 bar	04 stem connected with bellow; stem, balancing disc; bellow and seat ring - stainless steel
		15-200 mm	E 40 bar	31 stem connected with bellow, SDNR with spring; stem, SDNR, spring, bellow – stainless steel
		15-200 mm	E 40 bar	71 stem connected with bellow; stem, throttling disc; bellow and seat ring - stainless steel
234	I cast stainless steel G-X5CrNiMo19-11-2	15-100 mm	E 40 bar	01 stem connected with bellow; stem, disc, bellow and seat ring - stainless steel
		125-200 mm	E 40 bar	04 stem connected with bellow; stem, balancing disc; bellow and seat ring - stainless steel
		15-200 mm	E 40 bar	31 stem connected with bellow, SDNR with spring; stem, SDNR, spring, bellow – stainless steel
		15-200 mm	E 40 bar	71 stem connected with bellow; stem, throttling disc; bellow and seat ring - stainless steel
		15-100 mm	E 40 bar	01-H stem connected with bellow; stem, disc, bellow and seat ring - stainless steel, type for hydrogen
		125-200 mm	E 40 bar	04-H stem connected with bellow; stem, balancing disc; bellow and seat ring - stainless steel, type for hydrogen
		15-200 mm	E 40 bar	31-H stem connected with bellow, SDNR with spring; stem, SDNR, spring, bellow – stainless steel, type for hydrogen
15-200 mm	E 40 bar	71-H stem connected with bellow; stem, throttling disc; bellow and seat ring - stainless steel, type for hydrogen		

Data given can be changed without notice.

Edition 10/2023

FIG.234



ORDERING

Figure	Body material	Nominal diameter	Nominal pressure	Type
234	A Grey cast iron EN-GJL-250	15-150 mm	C 16 bar	01 stem connected with bellow; stem, disc, bellow and seat ring - stainless steel

Order example acc. index

234 A 050 C 01

Bellow sealed stop valves, ends flanged, form straight
 Grey cast iron EN-GJL-250
 Nominal diameter (mm)
 Nominal pressure PN 16
 Stem connected with bellow; stem, disc and seat ring stainless steel

234 A 050 C 01

Data given can be changed without notice.

Edition 10/2023

ZETKAMA Sp. z o.o.
 Ul. 3 Maja 12
 PL 57-410 Ścinawka Średnia

Tel. +48 74 8652 193
 Tel. +48 74 8652 111
 Fax +48 74 8652 199

E-mail export@zetkama.com.pl
www.zetkama.com

FULL LIFT SAFETY VALVE zARMAK



Body material	Nominal pressure	Nominal diameter	Max. temperature	Ex. index
A Grey cast iron	C 16 bar	DN 20-150	300°C	6301
A Grey cast iron	C 16 bar	DN 20-100	120°C	6301M
C Nodular cast iron	E 40 bar	DN 20-100	350°C	6301S
F Cast steel	E 40 bar	DN 20-150	400°C	6302
F Cast steel	E 40 bar	DN 20-100	120°C	6302M
R Cast stainless steel	E 40 bar	DN 20-100	300°C	6302CrNi
F Cast steel	F 63 bar	DN 20-400	400°C	6303
F Cast steel	G 100 bar	DN 25-100	400°C	6304

CE 0343

CE 1433

More information on page 27

FEATURES

- flange dimension according to PN-EN 1092
 - valves made according to PN-EN ISO 4126-1
 - high tightness
- For valve with soft sealing
- quiet work of valve
 - raised tightness of closure
 - protection of disc sealing surface against a lime scale settling as well as against any small mechanical dirt

APPLICATION *

* not all of the applications are suitable for all of the executions

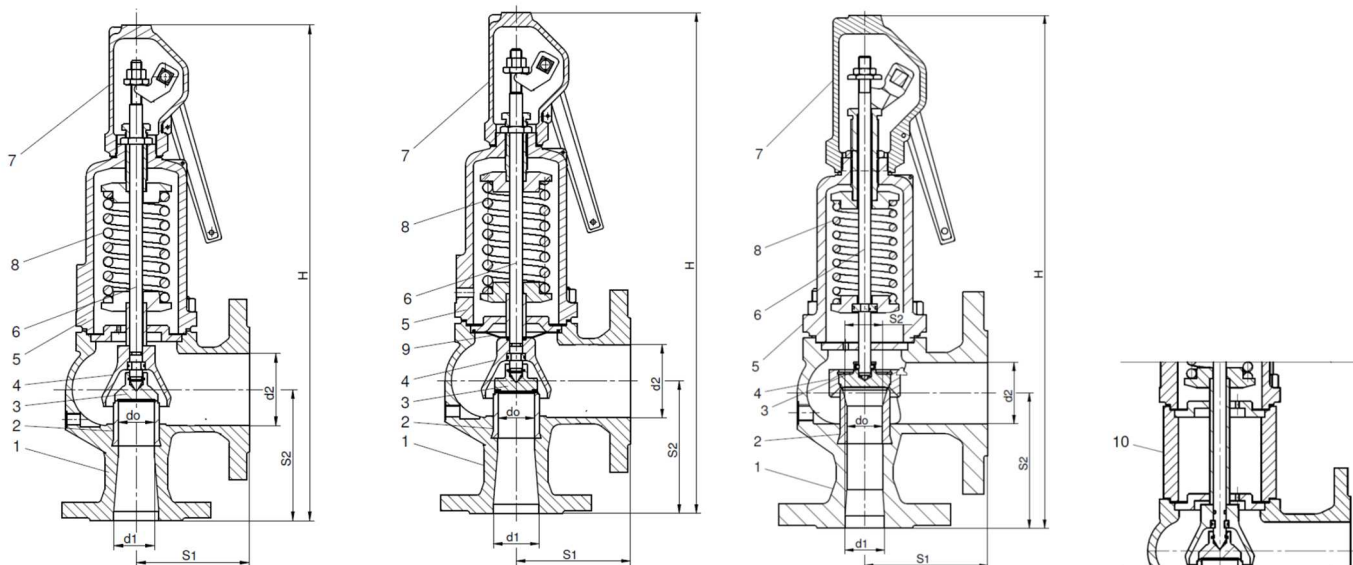
industries							
	INDUSTRY	SHIPBUILDING INDUSTRY	PETROCHEMICAL INDUSTRY	HEATING	REFRIGERATION AND AIR CONDITIONING	GAS	POWER ENGINEERING
media							
	DRINKING WATER	SEWAGE	GLYCOL	INDUSTRIAL WATER	STEAM	COMPRESSED AIR	NEUTRAL FLUIDS

Data given can be changed without notice.

Edition 01/2022

FIG.630

MATERIALS, DIMENSIONS PN16 AND PN40



01-1, 02-1, 03-1, 04-1, 05-1, 06-1, 07-1, 08-1, 01-2(3), 02-2(3), 03-2(3), 04-2(3), 05-2(3), 06-2(3), 07-2(3), 08-2(3)

01-4

51-1, 52-1, 53-1, 54-1, 55-1, 56-1, 57-1, 58-1

with insert

	Body material	A				C		
		standard	with soft sealing disc	with membrane	with extended seat	standard	with soft sealing disc	with extended seat
		01-1, 02-1, 03-1, 04-1 05-1, 06-1, 07-1, 08-1	01-2(3), 02-2(3), 03-2(3), 04-2(3), 05-2(3), 06-2(3), 07-2(3), 08-2(3)	01-4	51-1, 52-1, 53-1, 54-1 55-1, 56-1, 57-1, 58-1	01-1, 02-1, 03-1, 04-1 05-1, 06-1, 07-1, 08-1	01-2(3), 02-2(3), 03-2(3), 04-2(3), 05-2(3), 06-2(3), 07-2(3), 08-2(3)	51-1, 52-1, 53-1, 54-1 55-1, 56-1, 57-1, 58-1
1	Body	EN-GJL-250 5.1301				EN-GJS-400-18-LT 5.3103		
2	Seat	X39CrMo17-1 1.4122						
3	Disc	X39CrMo17-1 1.4122	X6CrNiTi18-10/EPDM or /NBR 1.4541/EPDM or /NBR		X39CrMo17-1 1.4122	X39CrMo17-1 1.4122	X6CrNiTi18-10/ EPDM or /NBR	X39CrMo17-1 1.4122
4	Bell	EN-GJS-400-15 5.3106			X20Cr13 1.4021	EN-GJS-400-15 5.3106		X20Cr13 1.4021
5	Bonnet	EN-GJL-250 / EN-GJS-400-15 5.1301 / 5.3106				EN-GJS-400-15 5.3106		
6	Spindle	X20Cr13* 1.4021						
7	Cap	EN-GJL-250 / EN-GJS-400-15 5.1301 / 5.3106				EN-GJS-400-15 5.3106		
8	Spring	51CrV4** 1.8159						
9	Membrane	-----		EPDM	-----			
Temperature range		-10...300°C***	-10...120°C EPDM -10...90°C NBR	-10...120°C	-10...300°C	-10...350°C	-10...120°C EPDM -10...90°C NBR	-10...350°C

* For marine type (05-, 06-, 07-, 08-, 55-, 56-,57-, 58-) spindle made of: X17CrNi16-2
 ** Springs with wire diameter up to Ø6 of patent wire, max. working temperature is 250°C
 *** For steam boilers are restrictions according to WUDT-UC-WO-M- it is 10 bar and 200°C

Data given can be changed without notice.

Edition 01/2022

ZETKAMA Sp. z o.o.
 Ul. 3 Maja 12
 PL 57-410 Ścinawka Średnia

Tel. +48 74 8652 193
 Tel. +48 74 8652 111
 Fax +48 74 8652 199

E-mail export@zetskama.com.pl
 www.zetskama.com

FIG.630

	Body material	F				R		
		Type	standard	with soft sealing disc	with membrane	with extended seat	standard	with extended seat
			01-1, 02-1, 03-1, 04-1 05-1, 06-1, 07-1, 08-1	01-2(3), 02-2(3), 03-2(3), 04-2(3), 05-2(3), 06-2(3), 07-2(3), 08-2(3)	01-4	51-1, 52-1, 53-1, 54-1 55-1, 56-1, 57-1, 58-1	02-1, 04-1	52-1, 54-1
1	Body	GP240GH 1.0619				GX5CrNi19-10 1.4308		
2	Seat	X39CrMo17-1 1.4122				X6CrNiTi18-10 1.4541		
3	Disc	X39CrMo17-1 1.4122	X6CrNiTi18-10/EPDM or /NBR 1.4541/EPDM or /NBR		X39CrMo17-1 1.4122	X6CrNiTi18-10 1.4541		
4	Bell	EN-GJS-400-15 5.3106			X20Cr13 1.4021	X6CrNiTi18-10 1.4541		
5	Bonnet	GP240GH 1.0619	EN-GJS-400-15 5.3106		GP240GH 1.0619	GX5CrNi19-10 1.4308		
6	Spindle	X20Cr13* 1.4021				X6CrNiTi18-10 1.4541		
7	Cap	EN-GJS-400-15 5.3106				GX5CrNi19-10 1.4308		
8	Spring	51CrV4** 1.8159				X10CrNi18-10 1.4310	51CrV4** 1.8159	
9	Membrane	-----		EPDM	-----			
10	Insert	P245GH 1.0352	-----					
Temperature range		-40...400 °C	-40...120°C EPDM -10...90°C NBR	-40...120°C	-40...400°C	-196...300°C		

* For marine type (05-, 06-, 07-, 08-, 55-, 56-, 57-, 58-) spindle made of: X17CrNi16-2
 ** Springs with wire diameter up to Φ6 of patent wire, max. working temperature is 250 °C

Body material		Type	A (PN16)																			
DN			20x32		25x40		32x50		40x65		50x80		65x100		80x125		100x150		125x200		150x250	
d ₀ (mm)			16	18	20	23	25	29	32	37	40	46	50	63	77	93	110					
A (mm ²)			201	254	314	416	491	661	804	1075	1257	1662	1964	3117	4657	6793	9503					
S ₁ (mm)			85		95		100		115		125		140		155		175		215		225	
S ₂ (mm)			95		105		110		130		145		150		170		180		220		245	
H (mm)			345		395		420		495		550		660		710		810		860		990	
Pressure at the beginning of bar opening (bar)	min	Standard / with extended seat	0,45																			
	max		16*														12,5	10				
	min	with membrane	0,45																			
	max		10																			
	min	with soft sealing disc	1																			
	max		16																			
Weight (kg)			7,5	9,0	13,0	19,0	25,0	37,0	52,0	77,0	90,0	140,0										

* For steam boilers are restrictions according to WUDT-UC-WO-M- it is 10 bar and 200 °C
 Type with extended seat marked in blue.
 Type for steam and gas valves with an extended seat up to DN40x65

Data given can be changed without notice.

Edition 01/2022

ZETKAMA Sp. z o.o.
 Ul. 3 Maja 12
 PL 57-410 Ścinawka Średnia

Tel. +48 74 8652 193
 Tel. +48 74 8652 111
 Fax +48 74 8652 199

E-mail export@zetkama.com.pl
 www.zetkama.com

FIG.630

Body material		Type	C (PN40)																				
DN			20x32		25x40		32x50		40x65		50x80		65x100		80x125		100x150		125x200		150x250		
d _o (mm)			16	18	20	23	25	29	32	37	40	46	50	63	77								
A (mm ²)			201	254	314	416	491	661	804	1075	1257	1662	1964	3117	4657								
S ₁ (mm)			85		95		100		115		125		140		155		175						
S ₂ (mm)			95		105		110		130		145		150		170		180						
H (mm)			345		395		420		495		550		660		710		810						
Pressure at the beginning of bar opening (bar)	min		Standard / with extended seat	0,45																			
	max	40*						32*						25*		20*							
		25*																					
	min	with soft sealing disc	1																				
max	40						32						25		20								
Weight (kg)		7,5		9,0		13,0		19,0		25,0		37,0		52,0		77,0							

* For steam boilers are restrictions according to WUDT-UC-WO-M- it is 10 bar and 200°C.

Type with extended seat marked in blue.

Type for steam and gas valves with an extended seat up to DN40x65

Body material		Type	F, R (PN40)																			
DN			20x32		25x40		32x50		40x65		50x80		65x100		80x125		100x150		125x200		150x250	
d _o (mm)			16	18	20	23	25	29	32	37	40	46	50	63	77	93	110					
A (mm ²)			201	254	314	416	491	661	804	1075	1257	1662	1964	3117	4657	6793	9503					
S ₁ (mm)			85		95		100		115		125		140		155		175		215		225	
S ₂ (mm)			95		105		110		130		145		150		170		180		220		245	
H (mm)	Without insert		345		395		420		495		550		660		710		810		860		990	
	With insert		405		465		495		585		655		770		840		955		970		-	
Pressure at the beginning of bar opening (bar)	min	Standard / with extended seat	0,45 (0,5)*																			
	max		40						32						25		20		12,5		10	
			25																			
	min	with membrane	0,45																			
	max		10																			
	min	with soft sealing disc	1																			
max	40						32						25		20							
Weight (kg)		8,0		10,0		14,0		20,0		27,0		39,0		55,0		82,0		100,0		155,0		

* The value in brackets applies to the body material R (standard type)

Type with extended seat marked in blue.

Type for steam and gas valves with an extended seat up to DN40x65

Type for body material R, diameter range from DN20x32 to 100x150

Data given can be changed without notice.

Edition 01/2022

ZETKAMA Sp. z o.o.
Ul. 3 Maja 12
PL 57-410 Ścinawka Średnia

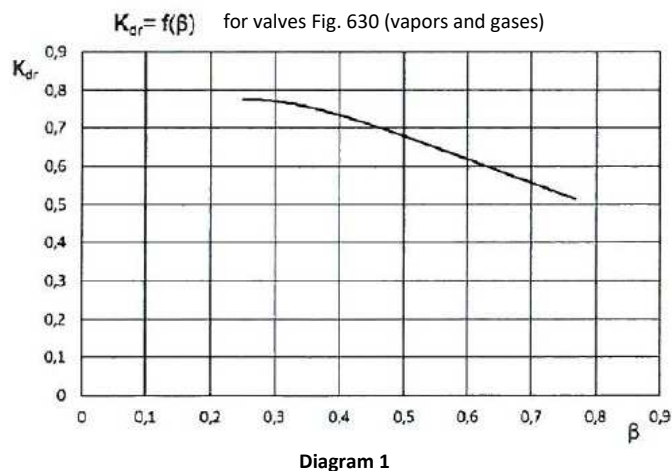
Tel. +48 74 8652 193
Tel. +48 74 8652 111
Fax +48 74 8652 199

E-mail export@zetkama.com.pl
www.zetkama.com

DISCHARGE COEFFICIENTS PN16 | PN40

Media	Range	DN											
		20x32	25x40	32x50	40x65	50x80	65x100	80x125	100x150	125x200	150x250		
Body material: A, C, F, R Standard type (01-1, 02-1, 03-1, 04-1, 05-1, 06-1, 07-1, 08-1) Type with soft sealing disc: 01-2(3), 02-2(3), 03-2(3), 04-2(3), 05-2(3), 06-2(3), 07-2(3), 08-2(3) Nominal pressure: PN16, PN40													
S/G	$b_1 = 0,1 \text{ bar for } p \leq 1 \text{ bar}$ $b_1 = 10\% \text{ for } 1 < p \leq 1,4 \text{ bar}$	0,72											
	$b_1 = 10\% \text{ for } p > 1,4 \text{ bar}$	0,78											
L	$b_1 = 10\% \text{ for } p \leq 6 \text{ bar}$	0,01											
	$b_1 = 10\% \text{ for } p > 6 \text{ bar}$	0,28											
S/G	$b_1 = 10\%$ type with limited disc leap	0,36											
Body material: A, F Type with membrane (01-4) Nominal pressure: PN16, PN40													
S/G	$b_1 = 0,1 \text{ bar for } p \leq 1 \text{ bar}$ $b_1 = 10\% \text{ for } 1 < p \leq 1,4 \text{ bar}$	0,72											
	$b_1 = 10\% \text{ for } p > 1,4 \text{ bar}$	0,78											
L	$b_1 = 0,1 \text{ bar for } p \leq 1 \text{ bar}$ $b_1 = 10\% \text{ for } p > 1 \text{ bar}$	0,50											
Body material: A, C, F, R Type with extended seat (53-1, 54-1, 56-1, 58-1) Nominal pressure: PN16, PN40													
L	$b_1 = 0,1 \text{ bar for } p \leq 1 \text{ bar}$ $b_1 = 10\% \text{ for } p > 1 \text{ bar}$	0,555				0,515							
S/G	$b_1 = 0,1 \text{ bar for } p \leq 1 \text{ bar}$ $b_1 = 10\% \text{ for } p > 1 \text{ bar}$	0,80*											
Body material: A, C, F, R Type with extended seat (51-1, 52-1, 55-1, 57-1) Nominal pressure: PN16, PN40													
S/G	$b_1 = 0,1 \text{ bar for } p \leq 1 \text{ bar}$ $b_1 = 10\% \text{ for } 1 < p < 3 \text{ bar}$	According to diagram 1, depending on the β coefficient											
	$b_1 = 10\% \text{ for } p \geq 3 \text{ bar}$	0,801											

* An acceptable ratio for vapors and gases for the calculation of bandwidth two-phase flow



Data given can be changed without notice.

Edition 01/2022

Dependence of the flow factor Kdr on the ratio of absolute pressures behind and before the valve
 For safety valves 630 DN 20-40 type 51-1, 52-1, 55-1, 57-1

DIMENSIONS OF SUPPORTED LUG PN40

Drill of supported lugs only onto client's request

DN	Body material: F All types Nominal pressure: PN40						
	A	B	C	L	E	d	s
	mm						
40x65	180	84	134	65	155	14	10
50x80	210	93	160	70	180	14	12
65x100	245	94	196	70	215	14	12
80x125	300	100	240	90	270	18	15
100x150	320	160	280	130	285	18	15
125x200	365	120	300	90	330	18	15
150x250	415	150	360	120	380	18	15

PRESSURE-TEMPERATURE RATINGS PN16 AND PN40

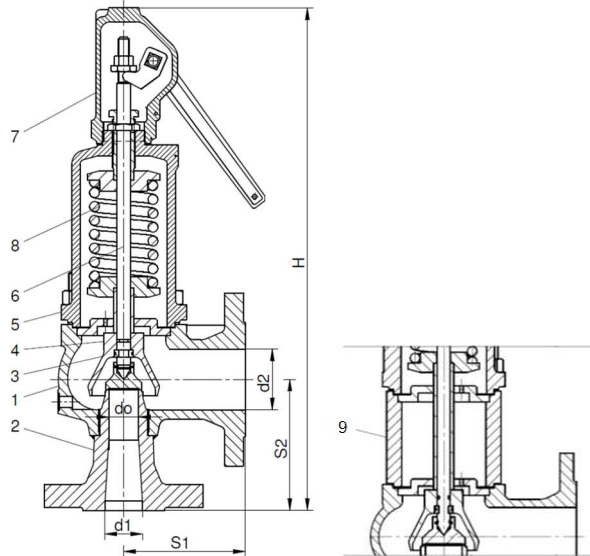
	PN		-40 (-10*)°C	RT	50 °C	100 °C	150 °C	200 °C	250 °C	300 °C	350 °C	400 °C
EN-GJL-250	16	bar	16	16	16	16	14,4	12,8	11,2	9,6		
EN-GJS-400-18-LT	40		40	40	40	40	38,8	36,8	34,8	32	28	
GP240GH			30	40	40	40	38,1	35	32	28	25,7	23,8
GX5CrNi19-10			38	37,6	35,6	27,6	24,9	22,6	21	19,6		

* The minimum temperature for cast iron valves

Data given can be changed without notice.

Edition 01/2022

MATERIALS, DIMENSIONS PN63 AND PN100



	Body material	F	
		standard	with soft seal
		01-1, 02-1, 03-1, 04-1, 05-1, 06-1, 07-1, 08-1	01-2(3), 02-2(3), 03-2(3), 04-2(3), 05-2(3), 06-2(3), 07-2(3), 08-2(3)
1	Body	GP240GH 1.0619	
2	Inlet nozzle	C22, P355N, 13CrMo4-5*, **** 1.0402, 1.0473, 1.7335	
3	Disc	X39CrMo17-1** 1.4122	X6CrNiTi18-10/EPDM or /NBR 1.4541/EPDM or /NBR
4	Bell	EN-GJS-400-15*** 5.3106	
5	Bonnet	GP240GH 1.0619	
6	Spindle	X20Cr13***** 1.4021	
7	Cap	EN-GJS-400-15*** 5.3106	
8	Spring	51CrV4 1.8159	
9	Insert	P245GH 1.0352	-----
Temperature range		-40...400°C	-40...120°C EPDM -10...90°C NBR

* Ex.6303 - from DN 125 GP240GH
 ** Ex.6303 - from DN 200 GX5CrNi19-10
 *** Ex.6303 - from DN 200 GP240GH
 **** For temperature under -10°C – nozzle - P355N
 ***** For marine type (05-, 06-, 07-, 08-) spindle - X17CrNi16-2

Data given can be changed without notice.

Edition 01/2022

ZETKAMA Sp. z o.o.
 Ul. 3 Maja 12
 PL 57-410 Ścinawka Średnia

Tel. +48 74 8652 193
 Tel. +48 74 8652 111
 Fax +48 74 8652 199

E-mail export@zetskama.com.pl
 www.zetskama.com

FIG.630

Body material		Type	F												
DN			20x25	25x40	32x50	40x65	50x80	65x100	80x125	100x150	125x200	150x250	200x300	300x400	400x500
d _o (mm)		630F F	16	20	25	32	40	50	63	77	93	110	155	220	280
A (mm ²)			201	314	491	804	1257	1964	3117	4657	6793	9503	18870	38010	61575
S ₁ (mm)			95	100	110	130	145	155	190	210	215	225	265	335	375
S ₂ (mm)			110	110	115	140	150	160	180	200	220	245	290	370	415
Flanges drilled PN-EN	inlet		63 (40*)						63 (40*) (25*)			40 (25*)	25		
	outlet	40 (25)								25 (10)		16	10		
H (mm)	without insert	400	420	475	535	650	685	790	940	980	1020	1210	1480	1650	
	with insert	470	495	560	640	760	815	935	----- **						
Pressure at the beginning of bar opening (bar)	min	Standard	38				30		23	18	12	9,5	0,45	0,3	0,25
	max		62				50		40	32	25	16	10	7	4,5
	min	with soft sealing disc	38				30		23	18					
	max		62				50		40	32					
Weight (kg)			12,0	14,0	20,0	28,0	40,0	50,0	80,0	130,0	150,0	180,0	300,0	470,0	550,0

* if the set pressure makes it possible - on client's request
 ** drill of outlet flange for PN 16
 *** type with insert for DN > 80, on client's request
 For temperatures above 350°C, type with insert is recommended.

Body material		Type	F						
DN			25x40	32x50	40x65	50x80	65x100	80x125	100x150
d _o (mm)		630F G	16	20	25	32	40	50	63
A (mm ²)			201	314	491	804	1257	1963	3117
S ₁ (mm)			100	110	130	145	155	190	210
S ₂ (mm)			120	125	140	150	165	185	200
Flanges drilled PN-EN	inlet		100						
	outlet	40							
H (mm)	without insert	430	485	535	650	685	795	940	
	with insert	505	570	640	760	812	940	----*	
Pressure at the beginning of bar opening (bar)	min	Standard	60			48		38	30
	max		95					78	62
	min	with soft sealing disc	60			48		38	30
	max		95					78	62
Weight (kg)			15,0	20,0	28,0	40,0	50,0	80,0	130,0

* type with insert for DN 100, on client's request
 For temperatures above 350°C, type with insert is recommended.
 Other types of flange drilling on client's request

Data given can be changed without notice.

Edition 01/2022

ZETKAMA Sp. z o.o.
 Ul. 3 Maja 12
 PL 57-410 Ścinawka Średnia

Tel. +48 74 8652 193
 Tel. +48 74 8652 111
 Fax +48 74 8652 199

E-mail export@zetkama.com.pl
 www.zetkama.com

DISCHARGE COEFFICIENTS PN63 I PN100

Media	Range	DN											
		20x25	25x40	32x50	40x65	50x80	65x100	80x125	100x150	125x200	150x250	200x300	300x400
Body material: F Standard type (01-1, 02-1, 03-1, 04-1, 05-1, 06-1, 07-1, 08-1) Type with soft sealing disc: 01-2(3), 02-2(3), 03-2(3), 04-2(3), 05-2(3), 06-2(3), 07-2(3), 08-2(3) Nominal pressure: PN63, PN100													
S/G	b ₁ = 10%	0,78										----	
	b ₁ = 0,1 bar for p ≤ 1 bar b ₁ = 10% for 1 < p ≤ 1,4 bar	----										0,70	0,54
	b ₁ = 10% for p > 1,4 bar	----										0,74	0,70
L	b ₁ = 10%	0,28										----	
	b ₁ = 0,1 bar for p ≤ 1 bar b ₁ = 10% for p > 1 bar	----										0,01	
S/G	b ₁ = 10% type with limited disc leap	0,36										----	

PRESSURE-TEMPERATURE RATINGS PN63 AND PN100

	PN		-40 ÷ 50°C	100 °C	150 °C	200 °C	250 °C	300 °C	350 °C	400 °C
	13CrMo4-5	63	bar	63	63	63	63	63	63	57
	100	100		100	100	100	100	100	90	86

DIMENSIONS OF SUPPORTED LUG PN63 AND PN100

Drill of supported lugs only onto client's request

	Body material: F All type Nominal pressure: PN63 i PN100*							
	DN	A	B	C	L	E	d	s
	mm							
40x65	186	93	140	70	90	156	14	12
50x80	210	95	165			180		
65x100	250	120	205			220		
80x125	295	120	150	240	120	260	18	15
100x150	320			265		285		
125x200	365			300		330		
150x250	415	180	360	150	380	23	20	
200x300	510	210	450	180	470			
300x400	695	230	600	180	655			
400x500	800		715	200	760			

* PN100 till DN100x150

Data given can be changed without notice.

Edition 01/2022

CAPACITY TABLE FOR AIR (TYPE 01, 02, 05, 07-1/2/3)

DNxDN PN100	25x40	32x50	40x65	50x80	65x100	80x125	100x150						
DNxDN PN16, PN40, PN63	20x32	25x40	32x50	40x65	50x80	65x100	80x125	100x150	125x200	150x250	200x300	300x400	400x500
A - flight computational area [mm ²]	201	314	491	804	1 257	1 964	3 117	4 657	6 793	9 503	18 870	38 010	61 575
Pressure at the beginning of bar opening bar(g)	Air 20°C [kg/h]												
0,45	185	289	451	739	1156	1806	2866	4281	6245	8737	16866	26208	42457
0,50	193	301	471	771	1205	1883	2988	4464	6512	9110	17587	27328	44270
0,55	200	313	489	801	1252	1956	3105	4639	6766	9466	18274	28396	46001
0,60	207	324	507	830	1297	2027	3217	4806	7010	9807	18933	29419	47659
0,70	221	345	540	884	1382	2160	3428	5121	7470	10450	20174	31348	50783
0,80	234	365	571	935	1461	2283	3624	5414	7898	11049	21330	33144	53693
0,90	246	384	601	984	1538	2404	3815	5699	8314	11630	22452	34889	56519
1,00	258	404	631	1033	1615	2524	4005	5984	8729	12212	23575	36633	59344
1,10	272	425	664	1087	1700	2656	4215	6298	9186	12851	24810	38552	62453
1,20	285	446	697	1141	1785	2788	4425	6611	9644	13491	26045	40471	65562
1,30	299	467	730	1196	1869	2920	4635	6925	10101	14131	27280	42390	68670
1,40	312	488	763	1250	1954	3053	4845	7238	10558	14770	28515	44309	71779
1,60	368	575	898	1471	2300	3593	5703	8521	12429	17387	32755	62412	101105
1,80	397	620	970	1588	2483	3880	6158	9200	13419	18773	35366	67387	109165
2,00	426	666	1042	1706	2667	4166	6612	9879	14410	20159	37977	72362	117224
2,20	456	712	1113	1823	2850	4453	7067	10558	15401	21545	40588	77337	125283
2,40	485	758	1185	1940	3033	4739	7521	11237	16392	22931	43198	82311	133342
2,60	514	803	1256	2057	3216	5026	7976	11917	17382	24317	45809	87286	141401
2,80	544	849	1328	2175	3400	5312	8431	12596	18373	25703	48420	92261	149460
3,00	573	895	1400	2292	3583	5598	8885	13275	19364	27089	51031	97236	157519
3,50	646	1010	1579	2585	4041	6315	10022	14973	21840	30553	57558	109673	177667
4,00	720	1124	1758	2878	4500	7031	11158	16671	24317	34018	64086	122110	197815
4,50	793	1239	1937	3171	4958	7747	12295	18369	26794	37483	70613	134548	217963
5,00	866	1353	2116	3464	5416	8463	13431	20067	29271	40948	77140	146985	
5,50	939	1467	2295	3758	5875	9179	14567	21765	31747	44413	83667	159422	
6,00	1013	1582	2474	4051	6333	9895	15704	23463	34224	47878	90195	171859	

Capacity calculated at overpressure $b_1 = 0,1$ bar or $b_1 = 10\%$

Data given can be changed without notice.

Edition 01/2022

ZETKAMA Sp. z o.o.
Ul. 3 Maja 12
PL 57-410 Ścinawka Średnia

Tel. +48 74 8652 193
Tel. +48 74 8652 111
Fax +48 74 8652 199

E-mail export@zetskama.com.pl
www.zetskama.com

CAPACITY TABLE FOR AIR (TYPE 01, 02, 05, 07-1/2/3)

DNxDN PN100	25x40	32x50	40x65	50x80	65x100	80x125	100x150						
DNxDN PN16, PN40, PN63	20x32	25x40	32x50	40x65	50x80	65x100	80x125	100x150	125x200	150x250	200x300	300x400	400x500
A - flight computational area [mm ²]	201	314	491	804	1 257	1 964	3 117	4 657	6 793	9 503	18 870	38 010	61 575
Pressure at the beginning of bar opening bar (g)	Air 20°C [kg/h]												
6,50	1086	1696	2653	4344	6791	10611	16840	25161	36701	51342	96722	184296	
7,00	1159	1811	2832	4637	7250	11327	17977	26859	39178	54807	103249	196733	
8,00	1306	2040	3190	5223	8166	12759	20250	30254	44131	61737	116303		
9,00	1452	2269	3548	5810	9083	14191	22523	33650	49085	68666	129358		
10,00	1599	2498	3906	6396	9999	15624	24796	37046	54038	75596	142412		
11,00	1746	2727	4264	6982	10916	17056	27069	40442	58992	82526			
12,00	1892	2956	4622	7568	11833	18488	29342	43838	63945	89455			
14,00	2185	3414	5338	8741	13666	21352	33887	50630	73852	103315			
16,00	2478	3872	6054	9913	15499	24217	38433	57422	83759	117174			
18,00	2772	4330	6770	11086	17332	27081	42979	64214	93666				
20,00	3065	4788	7486	12259	19166	29945	47525	71005	103573				
23,00	3504	5474	8560	14017	21915	34242	54344	81193	118434				
25,00	3798	5932	9276	15190	23749	37106	58890	87985	128341				
30,00	4530	7077	11067	18121	28332	44267	70254	104965					
32,00	4823	7535	11783	19294	30165	47131	74800	111756					
38,00	5703	8909	13931	22812	35665	55724	88438						
40,00	5996	9367	14647	23984	37498	58588	92984						
45,00	6729	10512	16437	26916	42081	65749	104348						
50,00	7462	11657	18227	29847	46664	72910	115713						
55,00	8195	12802	20018	32778	51247	80071	127078						
62,00	9221	14404	22524	36882	57663	90096	142988						
65,00	9660	15091	23598	38641	60413	94392							
70,00	10393	16236	25388	41573	64996	101553							
78,00	11566	18068	28253	46263	72329	113010							
86,00	12738	19900	31117	50953	79662								
95,00	14057	21960	34339	56230	87911								

Capacity calculated at overpressure $b_1 = 0,1$ bar or $b_1 = 10\%$

Data given can be changed without notice.

Edition 01/2022

ZETKAMA Sp. z o.o.
Ul. 3 Maja 12
PL 57-410 Ścinawka Średnia

Tel. +48 74 8652 193
Tel. +48 74 8652 111
Fax +48 74 8652 199

E-mail export@zetskama.com.pl
www.zetskama.com

CAPACITY TABLE FOR AIR FOR VALVE WITH MEMBRANE (TYPE 01-4)

DNxDN PN16, PN40*	20x32	25x40	32x50	40x65	50x80	65x100	80x125	100x150
A - flight computational area [mm ²]	201	314	491	804	1 257	1 964	3 117	4 657
Pressure at the beginning of bar opening bar (g)	Air 20°C [kg/h]							
0,45	185	289	451	739	1156	1806	2866	4281
0,50	193	301	471	771	1205	1883	2988	4464
0,55	200	313	489	801	1252	1956	3105	4639
0,60	207	324	507	830	1297	2027	3217	4806
0,65	214	335	524	857	1341	2095	3324	4967
0,70	221	345	540	884	1382	2160	3428	5121
0,75	227	355	556	910	1423	2223	3527	5270
0,80	234	365	571	935	1461	2283	3624	5414
0,85	240	375	586	959	1500	2344	3719	5557
0,90	246	384	601	984	1538	2404	3815	5699
0,95	252	394	616	1009	1577	2464	3910	5842
1,00	258	404	631	1033	1615	2524	4005	5984
1,10	272	425	664	1087	1700	2656	4215	6298
1,20	285	446	697	1141	1785	2788	4425	6611
1,30	299	467	730	1196	1869	2920	4635	6925
1,40	312	488	763	1250	1954	3053	4845	7238
1,50	353	552	863	1412	2208	3450	5476	8181
1,60	368	575	898	1471	2300	3593	5703	8521
1,70	382	597	934	1530	2392	3737	5930	8860
1,80	397	620	970	1588	2483	3880	6158	9200
1,90	412	643	1006	1647	2575	4023	6385	9539
2,00	426	666	1042	1706	2667	4166	6612	9879
2,20	456	712	1113	1823	2850	4453	7067	10558
2,40	485	758	1185	1940	3033	4739	7521	11237
2,60	514	803	1256	2057	3216	5026	7976	11917
2,80	544	849	1328	2175	3400	5312	8431	12596

* PN40 only for body material F

Capacity calculated at overpressure $b_1 = 0,1$ bar or $b_1 = 10\%$

Data given can be changed without notice.

Edition 01/2022

ZETKAMA Sp. z o.o.
Ul. 3 Maja 12
PL 57-410 Ścinawka Średnia

Tel. +48 74 8652 193
Tel. +48 74 8652 111
Fax +48 74 8652 199

E-mail export@zetkama.com.pl
www.zetkama.com

CAPACITY TABLE FOR AIR FOR VALVE WITH MEMBRANE (TYPE 01-4)

DNxDN PN16, PN40*	20x32	25x40	32x50	40x65	50x80	65x100	80x125	100x150
A - flight computational area [mm ²]	201	314	491	804	1 257	1 964	3 117	4 657
Pressure at the beginning of bar opening bar (g)	Air 20°C [kg/h]							
3,00	573	895	1400	2292	3583	5598	8885	13275
3,20	602	941	1471	2409	3766	5885	9340	13954
3,40	632	987	1543	2526	3950	6171	9794	14633
3,60	661	1032	1614	2644	4133	6458	10249	15312
3,80	690	1078	1686	2761	4316	6744	10703	15992
4,00	720	1124	1758	2878	4500	7031	11158	16671
4,50	793	1239	1937	3171	4958	7747	12295	18369
5,00	866	1353	2116	3464	5416	8463	13431	20067
5,50	939	1467	2295	3758	5875	9179	14567	21765
6,00	1013	1582	2474	4051	6333	9895	15704	23463
6,50	1086	1696	2653	4344	6791	10611	16840	25161
7,00	1159	1811	2832	4637	7250	11327	17977	26859
7,50	1233	1925	3011	4930	7708	12043	19113	28557
8,00	1306	2040	3190	5223	8166	12759	20250	30254
8,50	1379	2154	3369	5516	8624	13475	21386	31952
9,00	1452	2269	3548	5810	9083	14191	22523	33650
10,00	1599	2498	3906	6396	9999	15624	24796	37047

* PN40 only for body material F

Capacity calculated at overpressure $b_1 = 0,1$ bar or $b_1 = 10\%$

Data given can be changed without notice.

Edition 01/2022

CAPACITY TABLE FOR AIR FOR VALVE WITH EXTENDED SEAT (TYPE 51-, 52-, 55-, 57-1)

DNXDN PN16, PN40	20X32	25X40	32X50	40X65
A - flight computational area [mm ²]	254	416	661	1075
Pressure at the beginning of bar opening bar (g)	Air 20°C [KG/H]			
0,45	182	297	473	769
0,50	196	321	510	830
0,55	204	334	530	863
0,60	218	358	568	218
0,70	241	394	626	1 018
0,80	267	437	694	1 128
0,90	289	474	753	1 224
1,00	308	505	802	1 305
1,10	334	547	869	1 413
1,20	351	574	912	1 484
1,30	372	610	969	1 576
1,40	395	647	1 027	1 671
1,60	441	722	1 147	1 866
1,80	482	790	1 256	2 042
2,00	525	860	1 366	2 222
2,20	568	931	1 479	2 406
2,40	605	991	1 575	2 561
2,60	650	1 064	1 691	2 751
2,80	687	1 125	1 788	2 908
3,00	744	1 218	1 935	3 147
3,50	839	1 374	2 182	3 549
4,00	934	1 529	2 430	3 952
4,50	1 029	1 685	2 677	4 354
5,00	1 124	1 841	2 925	4 757
5,50	1 219	1 997	3 172	5 159
6,00	1 314	2 152	3 420	5 562

Capacity calculated at overpressure $b_1 = 0,1$ bar or $b_1 = 10\%$

Data given can be changed without notice.

Edition 01/2022

ZETKAMA Sp. z o.o.
Ul. 3 Maja 12
PL 57-410 Ścinawka Średnia

Tel. +48 74 8652 193
Tel. +48 74 8652 111
Fax +48 74 8652 199

E-mail export@zetskama.com.pl
www.zetskama.com

CAPACITY TABLE FOR AIR FOR VALVE WITH EXTENDED SEAT (TYPE 51-, 52-, 55-, 57-1)

DNxDN PN16, PN40	20x32	25x40	32x50	40x65
A - flight computational area [mm ²]	254	416	661	1075
Pressure at the beginning of bar opening bar (g)	Air 20°C [kg/h]			
6,5	1 409	2 308	3 667	5 964
7	1 504	2 464	3 915	6 367
8	1 695	2 775	4 410	7 172
9	1 885	3 087	4 905	7 977
10	2 075	3 398	5 400	8 782
11	2 265	3 710	5 895	9 587
12	2 455	4 021	6 390	10 392
14	2 836	4 644	7 380	12 002
16	3 216	5 267	8 370	13 612
18	3 597	5 890	9 360	15 222
20	3 977	6 514	10 350	16 832
23	4 548	7 448	11 835	19 247
25	4 928	8 071	12 825	20 857

Capacity calculated at overpressure $b_1 = 10\%$

Data given can be changed without notice.

Edition 01/2022

ZETKAMA Sp. z o.o.
Ul. 3 Maja 12
PL 57-410 Ścinawka Średnia

Tel. +48 74 8652 193
Tel. +48 74 8652 111
Fax +48 74 8652 199

E-mail export@zetskama.com.pl
www.zetskama.com

CAPACITY TABLE FOR WATER (TYPE 03-, 04-, 06-, 08- 1/2/3)

DNxDN PN100	25x40	32x50	40x65	50x80	65x100	80x125	100x150						
DNxDN PN16, PN40, PN63	20x32	25x40	32x50	40x65	50x80	65x100	80x125	100x150	125x200	150x250	200x300	300x400	400x500
A - flight computational area [mm ²]	201	314	491	804	1 257	1 964	3 117	4 657	6 793	9 503	18 870	38 010	61 575
Pressure at the beginning of bar opening bar (g)	Water 20°C [kg/h]												
0,45	71	111	176	290	456	716	1141	1711	2504	3511	7002	14157	22985
0,50	74	117	184	303	477	748	1193	1789	2617	3669	7317	14793	24016
0,55	77	122	191	316	496	779	1243	1863	2725	3821	7619	15403	25005
0,60	80	126	199	328	516	810	1290	1934	2830	3967	7910	15990	25956
0,70	86	135	213	351	552	867	1381	2070	3028	4245	8463	17104	27763
0,80	91	144	226	373	586	920	1466	2198	3214	4506	8981	18151	29460
0,90	96	152	239	394	619	971	1547	2318	3390	4752	9472	19141	31066
1,00	101	160	251	413	650	1019	1624	2433	3558	4987	9939	20083	32594
1,10	106	168	264	434	682	1070	1704	2553	3734	5234	10429	21071	34196
1,20	111	175	276	454	713	1118	1781	2668	3902	5469	10897	22016	35727
1,30	116	183	287	473	742	1165	1855	2779	4063	5695	11346	22922	37196
1,40	121	190	298	491	771	1209	1926	2885	4218	5912	11779	23794	38610
1,60	129	203	319	526	825	1294	2061	3087	4513	6325	12599	25449	41294
1,80	137	216	339	558	876	1374	2188	3277	4790	6712	13370	27004	43815
2,00	145	228	358	589	924	1449	2307	3456	5052	7079	14100	28475	46200
2,20	152	239	376	618	970	1521	2422	3627	5301	7428	14793	29874	48468
2,40	159	250	393	646	1014	1590	2531	3790	5539	7761	15456	31212	50636
2,60	166	260	409	673	1056	1656	2635	3946	5768	8081	16093	32494	52716
2,80	172	270	425	699	1097	1719	2736	4097	5987	8389	16705	33729	54717
3,00	178	280	440	724	1136	1780	2833	4242	6200	8686	17295	34920	56648
3,50	193	303	476	783	1228	1925	3063	4586	6701	9388	18691	37736	61212
4,00	207	324	510	838	1314	2059	3277	4906	7168	10042	19991	40357	65693
4,50	220	345	541	889	1395	2186	3478	5206	7607	10656	21212	42819	69678
5,00	232	364	571	938	1471	2305	3668	5490	8022	11237	22367	45148	
5,50	243	382	599	985	1544	2419	3849	5761	8417	11790	23466	47364	
6,00	254	399	626	1029	1614	2528	4021	6019	8794	12318	24516	49481	

Capacity calculated at overpressure $b_1 = 0,1$ bar or $b_1 = 10\%$

Data given can be changed without notice.

Edition 01/2022

ZETKAMA Sp. z o.o.
Ul. 3 Maja 12
PL 57-410 Ścinawka Średnia

Tel. +48 74 8652 193
Tel. +48 74 8652 111
Fax +48 74 8652 199

E-mail export@zetskama.com.pl
www.zetskama.com

CAPACITY TABLE FOR WATER (TYPE 03-, 04-, 06-, 08- 1/2/3)

DNxDN PN100	25x40	32x50	40x65	50x80	65x100	80x125	100x150						
DNxDN PN16, PN40, PN63	20x32	25x40	32x50	40x65	50x80	65x100	80x125	100x150	125x200	150x250	200x300	300x400	400x500
A - flight computational area [mm ²]	201	314	491	804	1 257	1 964	3 117	4 657	6 793	9 503	18 870	38 010	61 575
Pressure at the beginning of bar opening bar (g)	Water 20°C [kg/h]												
6,50	7654	11957	18698	30617	47867	74790	118697	177341	258681	361879	25524	51694	
7,00	7943	12409	19403	31772	49674	77613	123177	184035	268446	375539	26493	53646	
8,00	8492	13265	20743	33966	53104	82972	131682	196742	286980	401468	28333		
9,00	9007	14070	22001	36027	56325	88005	139670	208676	304389	425821	30062		
10,00	9494	14831	23191	37975	59372	92766	147225	219964	320854	448855	31697		
11,00	9957	15555	24323	39829	62270	97293	154411	230700	336514	470763			
12,00	10400	16247	25405	41600	65039	101620	161277	240959	351478	491696			
14,00	11233	17548	27440	44933	70250	109762	174199	260265	379639	531093			
16,00	12009	18760	29335	48035	75100	117340	186227	278235	405851	567762			
18,00	12737	19898	31115	50949	79656	124458	197523	295113	430470				
20,00	13426	20974	32798	53705	83965	131190	208208	311076	453756				
23,00	14398	22493	35172	57592	90042	140686	223278	333592	486599				
25,00	15011	23450	36669	60044	93875	146675	232784	347794	507314				
30,00	16444	25688	40169	65775	102835	160675	255002	380989					
32,00	16983	26531	41486	67932	106208	165944	263365	393484					
38,00	18507	28911	45208	74028	115737	180833	286995						
40,00	18988	29662	46383	75951	118744	185531	294451						
45,00	20139	31462	49196	80558	125947	196786	312312						
50,00	21229	33163	51858	84915	132760	207430	329206						
55,00	22265	34782	54389	89060	139239	217555	345274						
62,00	23639	36929	57746	94558	147835	230985	366588						
65,00	24205	37812	59127	96818	151369	236507							
70,00	25118	39240	61359	100473	157083	245435							
78,00	26515	41421	64770	106059	165817	259080							
86,00	27841	43494	68011	111366	174113								
95,00	29262	45713	71481	117048	182996								

Capacity calculated at overpressure $b_1 = 0,1$ bar or $b_1 = 10\%$

Data given can be changed without notice.

Edition 01/2022

CAPACITY TABLE FOR WATER FOR VALVE WITH MEMBRANE (TYPE 01-4)

DNxDN PN16, PN40*	20x32	25x40	32x50	40x65	50x80	65x100	80x125	100x150
A - flight computational area [mm ²]	201	314	491	804	1 257	1 964	3 117	4 657
Pressure at the beginning of bar opening bar (g)	Water 20°C [kg/h]							
0,45	3791	5922	9260	15163	23707	37041	58787	87831
0,50	3959	6185	9672	15838	24761	38688	61401	91737
0,55	4121	6438	10067	16484	25772	40268	63908	95483
0,60	4277	6681	10447	17107	26745	41788	66320	99087
0,65	4427	6915	10814	17707	27684	43255	68648	102565
0,70	4572	7142	11168	18288	28592	44673	70899	105928
0,75	4713	7362	11512	18851	29472	46048	73081	109188
0,80	4849	7576	11846	19397	30326	47383	75200	112354
0,85	4982	7783	12170	19929	31157	48682	77261	115433
0,90	5112	7985	12487	20446	31967	49946	79268	118432
0,95	5238	8182	12795	20951	32756	51180	81226	121356
1,00	5361	8375	13096	21444	33527	52384	83137	124212
1,10	5623	8784	13735	22491	35163	54941	87195	130275
1,20	5873	9174	14346	23491	36727	57384	91072	136067
1,30	6113	9549	14932	24450	38226	59727	94791	141624
1,40	6343	9909	15495	25373	39670	61982	98369	146970
1,50	6566	10257	16039	26264	41062	64157	101822	152128
1,60	6781	10594	16565	27125	42408	66261	105161	157117
1,70	6990	10920	17075	27960	43714	68300	108397	161953
1,80	7193	11236	17570	28771	44981	70281	111540	166648
1,90	7390	11544	18052	29559	46214	72206	114596	171214
2,00	7582	11844	18521	30327	47414	74082	117573	175662
2,20	7952	12422	19425	31807	49728	77698	123312	184236
2,40	8305	12975	20288	33221	51940	81153	128795	192428
2,60	8645	13504	21117	34578	54060	84467	134054	200286
2,80	8971	14014	21914	35883	56101	87655	139115	207847

* PN40 only for body material F

Capacity calculated at overpressure $b_1 = 0,1$ bar or $b_1 = 10\%$

Data given can be changed without notice.

Edition 01/2022

ZETKAMA Sp. z o.o.
Ul. 3 Maja 12
PL 57-410 Ścinawka Średnia

Tel. +48 74 8652 193
Tel. +48 74 8652 111
Fax +48 74 8652 199

E-mail export@zetkama.com.pl
www.zetkama.com

CAPACITY TABLE FOR WATER FOR VALVE WITH MEMBRANE (TYPE 01-4)

DNxDN PN16, PN40*	20x32	25x40	32x50	40x65	50x80	65x100	80x125	100x150
A - flight computational area [mm ²]	201	314	491	804	1 257	1 964	3 117	4 657
Pressure at the beginning of bar opening bar (g)	Water 20°C [kg/h]							
3,00	9286	14506	22683	37143	58070	90732	143997	215142
3,20	9590	14982	23427	38361	59975	93707	148720	222197
3,40	9885	15443	24148	39541	61820	96591	153297	229036
3,60	10172	15891	24848	40688	63613	99392	157741	235676
3,80	10451	16326	25529	41803	65356	102115	162064	242134
4,00	10722	16750	26192	42889	67054	104768	166274	248424
4,50	11373	17766	27781	45490	71121	111123	176360	263494
5,00	11988	18727	29284	47951	74968	117134	185900	277747
5,50	12573	19641	30713	50292	78627	122851	194974	291303
6,00	13132	20515	32079	52528	82124	128314	203643	304256
6,50	13668	21352	33388	54673	85477	133554	211959	316680
7,00	14184	22158	34649	56737	88704	138595	219960	328634
7,50	14682	22936	35865	58728	91817	143460	227680	340169
8,00	15163	23688	37041	60654	94828	148164	235147	351325
8,50	15630	24417	38181	62521	97747	152724	242384	362137
9,00	16083	25125	39288	64333	100581	157152	249411	372636
10,00	16953	26484	41413	67813	106022	165654	262903	392795

* PN40 only for body material F

Capacity calculated at overpressure $b_1 = 0,1$ bar or $b_1 = 10\%$

Data given can be changed without notice.

Edition 01/2022

CAPACITY TABLE FOR WATER FOR VALVE WITH EXTENDED SEAT (TYPE 53-, 54-, 56-, 58-1)

DNxDN PN16, PN40	20x32	25x40	32x50	40x65	50x80
A - flight computational area [mm ²]	254	416	661	1075	1662
Pressure at the beginning of bar opening bar (g)	Water 20°C [kg/h]				
0,45	5 317	8 709	13 838	22 505	32 286
0,50	5 554	9 096	14 453	23 505	33 721
0,55	5 781	9 467	15 043	24 465	35 098
0,60	5 999	9 825	15 611	25 389	36 423
0,70	6 413	10 503	16 689	27 142	38 938
0,80	6 802	11 140	17 701	28 788	41 300
0,90	7 170	11 743	18 659	30 345	43 534
1,00	7 520	12 316	19 570	31 827	45 659
1,10	7 887	12 917	20 525	33 380	47 887
1,20	8 238	13 492	21 437	34 864	50 017
1,30	8 574	14 043	22 313	36 288	52 059
1,40	8 898	14 573	23 155	37 658	54 024
1,60	9 512	15 579	24 754	40 258	57 754
1,80	10 089	16 524	26 255	42 700	61 258
2,00	10 635	17 418	27 676	45 009	64 571
2,20	11 154	18 268	29 026	47 206	67 723
2,40	11 650	19 080	30 317	49 305	70 735
2,60	12 126	19 859	31 555	51 319	73 623
2,80	12 583	20 609	32 746	53 256	76 402
3,00	13 025	21 332	33 896	55 125	79 084
3,50	14 069	23 041	36 611	59 542	85 420
4,00	15 040	24 632	39 139	63 653	91 318
4,50	15 952	26 126	41 513	67 514	96 857
5,00	16 815	27 540	43 759	71 166	102 096
5,50	17 636	28 884	45 895	74 640	107 080
6,00	18 420	30 168	47 936	77 959	111 841

Capacity calculated at overpressure $b_1 = 0,1$ bar or $b_1 = 10\%$

Data given can be changed without notice.

Edition 01/2022

ZETKAMA Sp. z o.o.
Ul. 3 Maja 12
PL 57-410 Ścinawka Średnia

Tel. +48 74 8652 193
Tel. +48 74 8652 111
Fax +48 74 8652 199

E-mail export@zetkama.com.pl
www.zetkama.com

CAPACITY TABLE FOR WATER FOR VALVE WITH EXTENDED SEAT (TYPE 53-, 54-, 56-, 58-1)

DNxDN PN16, PN40	20x32	25x40	32x50	40x65	50x80
A - flight computational area [mm ²]	254	416	661	1075	1662
Pressure at the beginning of bar opening bar (g)	Water 20°C [kg/h]				
6,50	19 172	31 400	49 893	81 142	116 408
7,00	19 896	32 585	51 776	84 205	120 802
8,00	21 270	34 835	55 351	90 019	129 143
9,00	22 560	36 948	58 709	95 480	136 977
10,00	23 780	38 947	61 885	100 644	144 386
11,00	24 941	40 848	64 905	105 557	151 434
12,00	26 050	42 664	67 791	110 250	158 167
14,00	28 137	46 083	73 223	119 084	170 840
16,00	30 080	49 264	78 278	127 306	182 636
18,00	31 904	52 253	83 027	135 028	193 714
20,00	33 630	55 079	87 518	142 332	204 193
23,00	36 064	59 066	93 853	152 635	218 973
25,00	37 600	61 581	97 848	159 133	228 295

Capacity calculated at overpressure $b_1 = 0,1$ bar or $b_1 = 10\%$

Data given can be changed without notice.

Edition 01/2022

ZETKAMA Sp. z o.o.
Ul. 3 Maja 12
PL 57-410 Ścinawka Średnia

Tel. +48 74 8652 193
Tel. +48 74 8652 111
Fax +48 74 8652 199

E-mail export@zetskama.com.pl
www.zetskama.com

CAPACITY TABLE FOR SATURATED VAPOURS (TYPE 01-, 02-, 06-, 08-1/2/3)

DNxDN PN100	25x40	32x50	40x65	50x80	65x100	80x125	100x150						
DNxDN PN16, PN40, PN63	20x32	25x40	32x50	40x65	50x80	65x100	80x125	100x150	125x200	150x250	200x300	300x400	400x500
A - flight computational area [mm ²]	201	314	491	804	1 257	1 964	3 117	4 657	6 793	9 503	18 870	38 010	61 575
Pressure at the beginning of bar opening (g)	Saturated vapors [kg/h]												
0,45	115	180	282	461	721	1127	1788	2672	3897	5452	10525	16355	26494
0,50	120	187	293	479	749	1171	1858	2777	4050	5666	10938	16997	27534
0,55	124	194	304	497	777	1214	1927	2879	4199	5875	11342	17624	28550
0,60	129	201	314	514	804	1257	1994	2980	4347	6081	11739	18241	29550
0,70	137	215	336	550	859	1343	2131	3184	4644	6497	12543	19491	31574
0,80	147	230	359	588	919	1436	2280	3406	4968	6950	13417	20849	33775
0,90	158	246	385	630	985	1540	2444	3651	5326	7450	14383	22350	36206
1,00	164	256	401	656	1026	1603	2545	3802	5546	7758	14977	23273	37702
1,10	171	268	419	686	1072	1675	2659	3972	5794	8106	15649	24317	39392
1,20	179	280	437	716	1120	1749	2776	4148	6051	8465	16341	25393	41135
1,30	187	292	457	748	1169	1826	2898	4330	6316	8836	17058	26506	42940
1,40	195	305	476	780	1220	1906	3025	4519	6592	9221	17802	27663	44813
1,60	230	360	562	921	1439	2249	3569	5332	7778	10881	20497	39056	63270
1,80	251	392	613	1004	1569	2452	3891	5813	8480	11863	22347	42581	68981
2,00	268	418	654	1071	1674	2615	4150	6201	9045	12654	23838	45421	73581
2,20	285	445	695	1138	1780	2781	4413	6594	9618	13456	25349	48300	78244
2,40	303	473	739	1210	1892	2956	4691	7009	10224	14303	26944	51340	83170
2,60	322	502	786	1286	2011	3142	4987	7451	10868	15204	28642	54576	88411
2,80	340	532	831	1361	2128	3326	5278	7885	11502	16091	30313	57759	93568
3,00	357	558	872	1428	2233	3489	5537	8273	12067	16881	31802	60596	98164
3,50	402	628	982	1609	2515	3929	6236	9317	13591	19012	35817	68246	110557
4,00	446	697	1090	1784	2790	4359	6918	10336	15077	21092	39734	75710	122647
4,50	492	768	1201	1967	3075	4805	7626	11393	16619	23249	43798	83454	135193
5,00	535	835	1306	2139	3344	5225	8292	12389	18072	25282	47627	90750	
5,50	580	906	1417	2320	3627	5667	8993	13437	19600	27419	51653	98421	
6,00	623	973	1521	2491	3895	6086	9658	14430	21049	29446	55473	105699	

Capacity calculated at overpressure $b_1 = 0,1$ bar or $b_1 = 10\%$

Data given can be changed without notice.

Edition 01/2022

ZETKAMA Sp. z o.o.
Ul. 3 Maja 12
PL 57-410 Ścinawka Średnia

Tel. +48 74 8652 193
Tel. +48 74 8652 111
Fax +48 74 8652 199

E-mail export@zetskama.com.pl
www.zetskama.com

CAPACITY TABLE FOR SATURATED VAPOURS (TYPE 01-, 02-, 06-, 08-1/2/3)

DNxDN PN100	25x40	32x50	40x65	50x80	65x100	80x125	100x150						
DNxDN PN16, PN40, PN63	20x32	25x40	32x50	40x65	50x80	65x100	80x125	100x150	125x200	150x250	200x300	300x400	400x500
A - flight computational area [mm ²]	201	314	491	804	1 257	1 964	3 117	4 657	6 793	9 503	18 870	38 010	61 575
Pressure at the beginning of bar opening (g)	Saturated vapors [kg/h]												
6,50	667	1042	1630	2669	4173	6520	10348	15461	22553	31550	59436	113250	
7,00	711	1110	1736	2843	4445	6945	11021	16467	24019	33602	63301	120615	
8,00	798	1247	1950	3193	4993	7801	12381	18498	26982	37746	71108		
9,00	886	1384	2165	3545	5542	8659	13742	20531	29948	41896	78926		
10,00	974	1521	2378	3894	6089	9513	15098	22558	32904	46031	86716		
11,00	1060	1657	2590	4242	6631	10361	16444	24568	35837	50134			
12,00	1147	1792	2802	4588	7173	11208	17787	26575	38764	54229			
14,00	1321	2063	3227	5283	8260	12906	20483	30603	44639	62447			
16,00	1494	2334	3650	5976	9344	14599	23169	34616	50494	70638			
18,00	1668	2605	4074	6671	10429	16295	25861	38638	56360				
20,00	1842	2877	4499	7366	11517	17995	28559	42669	62239				
23,00	2101	3282	5132	8403	13138	20527	32578	48673	70998				
25,00	2275	3553	5556	9098	14224	22225	35272	52699	76871				
30,00	2711	4235	6622	10843	16953	26488	42038	62808					
32,00	2884	4506	7046	11538	18038	28184	44730	66830					
38,00	3407	5322	8322	13627	21305	33288	52830						
40,00	3583	5597	8752	14331	22406	35008	55560						
45,00	4026	6289	9834	16102	25175	39334	62426						
50,00	4462	6971	10900	17848	27905	43600	69196						
55,00	4913	7675	12001	19651	30723	48003	76184						
62,00	5532	8643	13515	22130	34598	54058	85794						
65,00	5795	9053	14156	23181	36242	56626							
70,00	6247	9758	15259	24986	39064	61036							
78,00	6971	10891	17029	27885	43597	68118							
86,00	7698	12026	18806	30794	48144								
95,00	8540	13341	20862	34161	53408								

Capacity calculated at overpressure $b_1 = 0,1$ bar or $b_1 = 10\%$

Data given can be changed without notice.

Edition 01/2022

**CAPACITY TABLE FOR SATURATED VAPOURS FOR VALVE WITH EXTENDED SEAT
(TYPE 51-, 52-, 56-, 58-1/2/3)**

DNxDN PN16, PN40	20x32	25x40	32x50	40x65
A - flight computational area [mm ²]	254	416	661	1075
Pressure at the beginning of bar opening (g)	Saturated vapors [kg/h]			
0,45	113	186	295	480
0,50	122	200	317	516
0,55	126	207	329	535
0,60	135	222	352	573
0,70	150	245	389	633
0,80	168	275	436	710
0,90	185	303	482	784
1,00	196	321	510	829
1,10	211	345	548	891
1,20	220	360	572	931
1,30	233	381	606	986
1,40	246	404	641	1 043
1,60	276	452	718	1 168
1,80	305	499	793	1 290
2,00	330	540	858	1 395
2,20	355	581	924	1 503
2,40	377	618	982	1 597
2,60	406	666	1 058	1 720
2,80	430	704	1 119	1 820
3,00	463	759	1 206	1 961
3,50	522	855	1 358	2 209
4,00	579	948	1 507	2 450
4,50	638	1 045	1 661	2 701
5,00	694	1 137	1 806	2 937
5,50	753	1 233	1 959	3 185
6,00	808	1 324	2 103	3 421

Capacity calculated at overpressure $b_1 = 0,1$ bar or $b_1 = 10\%$

Data given can be changed without notice.

Edition 01/2022

ZETKAMA Sp. z o.o.
Ul. 3 Maja 12
PL 57-410 Ścinawka Średnia

Tel. +48 74 8652 193
Tel. +48 74 8652 111
Fax +48 74 8652 199

E-mail export@zetkama.com.pl
www.zetkama.com

**CAPACITY TABLE FOR SATURATED VAPOURS FOR VALVE WITH EXTENDED SEAT
(TYPE 51-, 52-, 56-, 58-1/2/3)**

DNxDN PN16, PN40	20x32	25x40	32x50	40x65
A - flight computational area [mm ²]	254	416	661	1075
Pressure at the beginning of bar opening (g)	Saturated vapors [kg/h]			
6,5	866	1 418	2 254	3 665
7	922	1 511	2 400	3 903
8	1 036	1 697	2 696	4 385
9	1 150	1 883	2 993	4 867
10	1 263	2 069	3 288	5 347
11	1 376	2 254	3 581	5 824
12	1 488	2 438	3 874	6 300
14	1 714	2 807	4 461	7 254
16	1 939	3 175	5 046	8 206
18	2 164	3 544	5 632	9 159
20	2 390	3 914	6 219	10 115
23	2 726	4 465	7 095	11 538
25	2 952	4 834	7 681	12 492

Capacity calculated at overpressure $b_1 = 10\%$

Data given can be changed without notice.

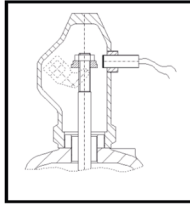
Edition 01/2022

ZETKAMA Sp. z o.o.
Ul. 3 Maja 12
PL 57-410 Ścinawka Średnia

Tel. +48 74 8652 193
Tel. +48 74 8652 111
Fax +48 74 8652 199

E-mail export@zetkama.com.pl
www.zetkama.com

OPTIONS



Type with inductive sensor with operation alert

Operation range:
depending on the type and diameter of the valve

Supply voltage:
10 ÷ 30 V [DC]

Degree of protection:
IP67, IP68 (depending on sensor type)

Operating temperature:
-25 ÷ 70°C

Other upon agreement with the manufacturer

Standard cable length
2000 mm



The product meets the requirements of the following standards

PN-EN 1127-1:2019-10
PN-EN ISO 80079-36:2016-07
PN-EN ISO 80079-37:2016-07

The product is labelled:



II 2G Ex h IIC TX Gb

NOTE:

ATEX type does not include valves with soft tightening for disc



Standard flanges valves are drilled according to standards

PN-EN 1092-1 cast steel
PN-EN 1092-2 cast iron

Upon client's request, it is possible to make flange drillings according to ANSI standards or according to European standards other than basic ones (after consultation with the manufacturer)

ATTENTION

- In the case of when condensate forms, provide drainage in the lowest spot of blow-out installation. Drainage in the body valve is made only upon request of the customer. For liquids, blow-out installation should be made in a tilted way.
- Valves should be mounted in a vertical position.

Data given can be changed without notice.

Edition 01/2022

TYPE

Figure	Body material	Nominal diameter	Nominal pressure	Type	Notified unit
630	A Grey cast iron EN-GJL-250	20-150 mm	C 16 bar	01-1 normal type for gases and vapors; sealing metal/metal	CE 0343
		20-150 mm	C 16 bar	02-1 gas tight type for gases and vapors; sealing metal/metal	CE 0343
		20-150 mm	C 16 bar	03-1 type with limited disc leap for liquids; sealing metal/metal	CE 1433
		20-150 mm	C 16 bar	04-1 type with limited disc leap for liquids, gases and vapors, sealing metal/metal	CE 1433
		20-150 mm	C 16 bar	05-1 marine type for gases and vapors, sealing metal/metal	CE 0343
		20-150 mm	C 16 bar	06-1 marine type with limited disc leap for liquids, gases and vapors, sealing metal/metal	CE 1433
		20-150 mm	C 16 bar	07-1 marine type, gas-tight for gases and vapors, sealing metal/metal	CE 0343
		20-150 mm	C 16 bar	08-1 marine type, gas-tight with limited disc leap for liquids, gases and vapors sealing metal/metal	CE 1433
		20-40 mm	C 16 bar	51-1 type with extended seat for gases and vapors; sealing metal/metal	CE 1433
		20-40 mm	C 16 bar	52-1 type with extended seat, gas tight type for gases and vapors; sealing metal/metal	CE 1433
		20-50 mm	C 16 bar	53-1 type with extended seat for liquids; sealing metal/metal	CE 1433
		20-50 mm	C 16 bar	54-1 type with extended seat gas-tight for liquids, sealing metal/metal	CE 1433
		20-40 mm	C 16 bar	55-1 type with extended seat, marine type for gases and vapors, sealing metal/metal	CE 1433
		20-50 mm	C 16 bar	56-1 type with extended seat, marine for liquids sealing metal/metal	CE 1433
		20-40 mm	C 16 bar	57-1 type with extended seat, marine type, gas-tight for gases and vapors, sealing metal/metal	CE 1433
		20-50 mm	C 16 bar	58-1 type with extended seat gas-tight, marine, for liquids sealing metal/metal	CE 1433
		20-100 mm	C 16 bar	01-2 normal type for gases and vapours; sealing NBR	CE 0343
		20-100 mm	C 16 bar	02-2 gas tight type for gases and vapours; sealing NBR	CE 0343
		20-100 mm	C 16 bar	03-2 type with limited disc leap for liquids; sealing NBR	CE 1433
		20-100 mm	C 16 bar	04-2 type with limited disc leap for liquids, gases and vapours, sealing NBR	CE 1433
		20-100 mm	C 16 bar	05-2 marine type for gases and vapours, sealing NBR	CE 0343
		20-100 mm	C 16 bar	06-2 marine type with limited disc leap for liquids, gases and vapours, sealing NBR	CE 1433
		20-100 mm	C 16 bar	07-2 marine type, gas-tight for gases and vapours, sealing NBR	CE 0343

Data given can be changed without notice.

Edition 01/2022

FIG.630

	20-100 mm	C 16 bar	08-2 marine type, gas-tight with limited disc leap for liquids, gases and vapours sealing NBR	CE 1433	
	20-100 mm	C 16 bar	01-3 normal type for gases and vapours; sealing EPDM	CE 0343	
	20-100 mm	C 16 bar	02-3 gas tight type for gases and vapours; sealing EPDM	CE 0343	
	20-100 mm	C 16 bar	03-3 type with limited disc leap for liquids; sealing EPDM	CE 1433	
	20-100 mm	C 16 bar	04-3 type with limited disc leap for liquids, gases and vapours, sealing EPDM	CE 1433	
	20-100 mm	C 16 bar	05-3 marine type for gases and vapours, sealing EPDM	CE 0343	
	20-100 mm	C 16 bar	06-3 marine type with limited disc leap for liquids, gases and vapours, sealing EPDM	CE 1433	
	20-100 mm	C 16 bar	07-3 marine type, gas-tight for gases and vapours, sealing EPDM	CE 0343	
	20-100 mm	C 16 bar	08-3 marine type, gas-tight with limited disc leap for liquids, gases and vapours sealing EPDM	CE 1433	
	20-100 mm	C 16 bar	01-4 normal type for liquids, gases and vapours, membrane, sealing EPDM	CE 0343	
630	C Nodular cast iron EN-GJS-400-18-LT	20-100 mm	E 40 bar	01-1 normal type for gases and vapours; sealing metal/metal	CE 0343
20-100 mm		E 40 bar	02-1 gas tight type for gases and vapours; sealing metal/metal	CE 0343	
20-100 mm		E 40 bar	03-1 type with limited disc leap for liquids; sealing metal/metal	CE 0343	
20-100 mm		E 40 bar	04-1 type with limited disc leap for liquids, gases and vapours, sealing metal/metal	CE 0343	
20-100 mm		E 40 bar	05-1 marine type for gases and vapours, sealing metal/metal	CE 0343	
20-100 mm		E 40 bar	06-1 marine type with limited disc leap for liquids, gases and vapours, sealing metal/metal	CE 0343	
20-100 mm		E 40 bar	07-1 marine type, gas-tight for gases and vapours, sealing metal/metal	CE 0343	
20-100 mm		E 40 bar	08-1 marine type, gas-tight with limited disc leap for liquids, gases and vapours sealing metal/metal	CE 0343	
20-40 mm		E 40 bar	51-1 type with extended seat for gases and vapors; sealing metal/metal	CE 1433	
20-40 mm		E 40 bar	52-1 type with extended seat, gas tight type for gases and vapors; sealing metal/metal	CE 1433	
20-50 mm		E 40 bar	53-1 type with extended seat for liquids; sealing metal/metal	CE 1433	
20-50 mm		E 40 bar	54-1 type with extended seat gas-tight for liquids, sealing metal/metal	CE 1433	
20-40 mm		E 40 bar	55-1 type with extended seat, marine type for gases and vapors, sealing metal/metal	CE 1433	
20-50 mm		E 40 bar	56-1 type with extended seat, marine for liquids sealing metal/metal	CE 1433	
20-40 mm		E 40 bar	57-1 type with extended seat, marine type, gas-tight for gases and vapors, sealing metal/metal	CE 1433	
20-50 mm		E 40 bar	58-1 type with extended seat gas-tight, marine, for liquids sealing metal/metal	CE 1433	

Data given can be changed without notice.

Edition 01/2022

FIG.630

	20-100 mm	E 40 bar	01-2 normal type for gases and vapours; sealing NBR	CE 0343
	20-100 mm	E 40 bar	02-2 gas tight type for gases and vapours; sealing NBR	CE 0343
	20-100 mm	E 40 bar	03-2 type with limited disc leap for liquids; sealing NBR	CE 0343
	20-100 mm	E 40 bar	04-2 type with limited disc leap for liquids, gases and vapours, sealing NBR	CE 0343
	20-100 mm	E 40 bar	05-2 marine type for gases and vapours, sealing NBR	CE 0343
	20-100 mm	E 40 bar	06-2 marine type with limited disc leap for liquids, gases and vapours, sealing NBR	CE 0343
	20-100 mm	E 40 bar	07-2 marine type, gas-tight for gases and vapours, sealing NBR	CE 0343
	20-100 mm	E 40 bar	08-2 marine type, gas-tight with limited disc leap for liquids, gases and vapours sealing NBR	CE 0343
	20-100 mm	E 40 bar	01-3 normal type for gases and vapours; sealing EPDM	CE 0343
	20-100 mm	E 40 bar	02-3 gas tight type for gases and vapours; sealing EPDM	CE 0343
	20-100 mm	E 40 bar	03-3 type with limited disc leap for liquids; sealing EPDM	CE 0343
	20-100 mm	E 40 bar	04-3 type with limited disc leap for liquids, gases and vapours, sealing EPDM	CE 0343
	20-100 mm	E 40 bar	05-3 marine type for gases and vapours, sealing EPDM	CE 0343
	20-100 mm	E 40 bar	06-3 marine type with limited disc leap for liquids, gases and vapours, sealing EPDM	CE 0343
	20-100 mm	E 40 bar	07-3 marine type, gas-tight for gases and vapours, sealing EPDM	CE 0343
	20-100 mm	E 40 bar	08-3 marine type, gas-tight with limited disc leap for liquids, gases and vapours sealing EPDM	CE 0343
630	F Cast steel GP240GH			
	20-150 mm	E 40 bar	01-1 normal type for gases and vapours; sealing metal/metal	CE 0343*
	20-150 mm	E 40 bar	02-1 gas tight type for gases and vapours; sealing metal/metal	CE 0343*
	20-150 mm	E 40 bar	03-1 type with limited disc leap for liquids; sealing metal/metal	CE 1433
	20-150 mm	E 40 bar	04-1 type with limited disc leap for liquids, gases and vapours, sealing metal/metal	CE 1433
	20-150 mm	E 40 bar	05-1 marine type for gases and vapours, sealing metal/metal	CE 0343*
	20-150 mm	E 40 bar	06-1 marine type with limited disc leap for liquids, gases and vapours, sealing metal/metal	CE 1433
	20-150 mm	E 40 bar	07-1 marine type, gas-tight for gases and vapours, sealing metal/metal	CE 0343*
	20-150 mm	E 40 bar	08-1 marine type, gas-tight with limited disc leap for liquids, gases and vapours sealing metal/metal	CE 1433
	20-40 mm	E 40 bar	51-1 type with extended seat for gases and vapors; sealing metal/metal	CE 1433
	20-40 mm	E 40 bar	52-1 type with extended seat, gas tight type for gases and vapors; sealing metal/metal	CE 1433

Data given can be changed without notice.

Edition 01/2022

FIG.630

	20-50 mm	E 40 bar	53-1 type with extended seat for liquids; sealing metal/metal	CE 1433
	20-50 mm	E 40 bar	54-1 type with extended seat gas-tight for liquids, sealing metal/metal	CE 1433
	20-40 mm	E 40 bar	55-1 type with extended seat, marine type for gases and vapors, sealing metal/metal	CE 1433
	20-50 mm	E 40 bar	56-1 type with extended seat, marine for liquids sealing metal/metal	CE 1433
	20-40 mm	E 40 bar	57-1 type with extended seat, marine type, gas-tight for gases and vapors, sealing metal/metal	CE 1433
	20-50 mm	E 40 bar	58-1 type with extended seat gas-tight, marine, for liquids sealing metal/metal	CE 1433
	20-100 mm	E 40 bar	01-2 normal type for gases and vapours; sealing NBR	CE 0343
	20-100 mm	E 40 bar	02-2 gas tight type for gases and vapours; sealing NBR	CE 0343
	20-100 mm	E 40 bar	03-2 type with limited disc leap for liquids; sealing NBR	CE 1433
	20-100 mm	E 40 bar	04-2 type with limited disc leap for liquids, gases and vapours, sealing NBR	CE 1433
	20-100 mm	E 40 bar	05-2 marine type for gases and vapours, sealing NBR	CE 0343
	20-100 mm	E 40 bar	06-2 marine type with limited disc leap for liquids, gases and vapours, sealing NBR	CE 1433
	20-100 mm	E 40 bar	07-2 marine type, gas-tight for gases and vapours, sealing NBR	CE 0343
	20-100 mm	E 40 bar	08-2 marine type, gas-tight with limited disc leap for liquids, gases and vapours sealing NBR	CE 1433
	20-100 mm	E 40 bar	01-3 normal type for gases and vapours; sealing EPDM	CE 0343
	20-100 mm	E 40 bar	02-3 gas tight type for gases and vapours; sealing EPDM	CE 0343
	20-100 mm	E 40 bar	03-3 type with limited disc leap for liquids; sealing EPDM	CE 1433
	20-100 mm	E 40 bar	04-3 type with limited disc leap for liquids, gases and vapours, sealing EPDM	CE 1433
	20-100 mm	E 40 bar	05-3 marine type for gases and vapours, sealing EPDM	CE 0343
	20-100 mm	E 40 bar	06-3 marine type with limited disc leap for liquids, gases and vapours, sealing EPDM	CE 1433
	20-100 mm	E 40 bar	07-3 marine type, gas-tight for gases and vapours, sealing EPDM	CE 0343
	20-100 mm	E 40 bar	08-3 marine type, gas-tight with limited disc leap for liquids, gases and vapours sealing EPDM	CE 1433
	20-100 mm	E 40 bar	01-4 normal type for liquids, gases and vapours, membrane, sealing EPDM	CE 1433
630	F Cast steel GP240GH			
	20-400 mm	F 63 bar	01-1 normal type for gases and vapours; sealing metal/metal	CE 0343*
	20-400 mm	F 63 bar	02-1 gas tight type for gases and vapours; sealing metal/metal	CE 0343*
	20-400 mm	F 63 bar	03-1 type with limited disc leap for liquids; sealing metal/metal	CE 1433

Data given can be changed without notice.

Edition 01/2022

FIG.630

	20-400 mm	F 63 bar	04-1 type with limited disc leap for liquids, gases and vapours, sealing metal/metal	CE 1433
	20-400 mm	F 63 bar	05-1 marine type for gases and vapours, sealing metal/metal	CE 0343*
	20-400 mm	F 63 bar	06-1 marine type with limited disc leap for liquids, gases and vapours, sealing metal/metal	CE 1433
	20-400 mm	F 63 bar	07-1 marine type, gas-tight for gases and vapours, sealing metal/metal	CE 0343*
	20-400 mm	F 63 bar	08-1 marine type, gas-tight with limited disc leap for liquids, gases and vapours sealing metal/metal	CE 1433
	20-100 mm	F 63 bar	01-2 normal type for gases and vapours; sealing NBR	CE 1433
	20-100 mm	F 63 bar	02-2 gas tight type for gases and vapours; sealing NBR	CE 1433
	20-100 mm	F 63 bar	03-2 type with limited disc leap for liquids; sealing NBR	CE 1433
	20-100 mm	F 63 bar	04-2 type with limited disc leap for liquids, gases and vapours, sealing NBR	CE 1433
	20-100 mm	F 63 bar	05-2 marine type for gases and vapours, sealing NBR	CE 1433
	20-100 mm	F 63 bar	06-2 marine type with limited disc leap for liquids, gases and vapours, sealing NBR	CE 1433
	20-100 mm	F 63 bar	07-2 marine type, gas-tight for gases and vapours, sealing NBR	CE 1433
	20-100 mm	F 63 bar	08-2 marine type, gas-tight with limited disc leap for liquids, gases and vapours sealing NBR	CE 1433
	20-100 mm	F 63 bar	01-3 normal type for gases and vapours; sealing EPDM	CE 1433
	20-100 mm	F 63 bar	02-3 gas tight type for gases and vapours; sealing EPDM	CE 1433
	20-100 mm	F 63 bar	03-3 type with limited disc leap for liquids; sealing EPDM	CE 1433
	20-100 mm	F 63 bar	04-3 type with limited disc leap for liquids, gases and vapours, sealing EPDM	CE 1433
	20-100 mm	F 63 bar	05-3 marine type for gases and vapours, sealing EPDM	CE 1433
	20-100 mm	F 63 bar	06-3 marine type with limited disc leap for liquids, gases and vapours, sealing EPDM	CE 1433
	20-100 mm	F 63 bar	07-3 marine type, gas-tight for gases and vapours, sealing EPDM	CE 1433
	20-100 mm	F 63 bar	08-3 marine type, gas-tight with limited disc leap for liquids, gases and vapours sealing EPDM	CE 1433
630	F Cast steel GP240GH			
	25-100 mm	G 100 bar	01-1 normal type for gases and vapours; sealing metal/metal	CE 1433
	25-100 mm	G 100 bar	02-1 gas tight type for gases and vapours; sealing metal/metal	CE 1433
	25-100 mm	G 100 bar	03-1 type with limited disc leap for liquids; sealing metal/metal	CE 1433
	25-100 mm	G 100 bar	04-1 type with limited disc leap for liquids, gases and vapours, sealing metal/metal	CE 1433
	25-100 mm	G 100 bar	05-1 marine type for gases and vapours, sealing metal/metal	CE 1433

Data given can be changed without notice.

Edition 01/2022

FIG.630

	25-100 mm	G	100 bar	06-1 marine type with limited disc leap for liquids, gases and vapours, sealing metal/metal	CE 1433
	25-100 mm	G	100 bar	07-1 marine type, gas-tight for gases and vapours, sealing metal/metal	CE 1433
	25-100 mm	G	100 bar	08-1 marine type, gas-tight with limited disc leap for liquids, gases and vapours sealing metal/metal	CE 1433
	25-100 mm	G	100 bar	01-2 normal type for gases and vapours; sealing NBR	CE 1433
	25-100 mm	G	100 bar	02-2 gas tight type for gases and vapours; sealing NBR	CE 1433
	25-100 mm	G	100 bar	03-2 type with limited disc leap for liquids; sealing NBR	CE 1433
	25-100 mm	G	100 bar	04-2 type with limited disc leap for liquids, gases and vapours, sealing NBR	CE 1433
	25-100 mm	G	100 bar	05-2 marine type for gases and vapours, sealing NBR	CE 1433
	25-100 mm	G	100 bar	06-2 marine type with limited disc leap for liquids, gases and vapours, sealing NBR	CE 1433
	25-100 mm	G	100 bar	07-2 marine type, gas-tight for gases and vapours, sealing NBR	CE 1433
	25-100 mm	G	100 bar	08-2 marine type, gas-tight with limited disc leap for liquids, gases and vapours sealing NBR	CE 1433
	25-100 mm	G	100 bar	01-3 normal type for gases and vapours; sealing EPDM	CE 1433
	25-100 mm	G	100 bar	02-3 gas tight type for gases and vapours; sealing EPDM	CE 1433
	25-100 mm	G	100 bar	03-3 type with limited disc leap for liquids; sealing EPDM	CE 1433
	25-100 mm	G	100 bar	04-3 type with limited disc leap for liquids, gases and vapours, sealing EPDM	CE 1433
	25-100 mm	G	100 bar	05-3 marine type for gases and vapours, sealing EPDM	CE 1433
	25-100 mm	G	100 bar	06-3 marine type with limited disc leap for liquids, gases and vapours, sealing EPDM	CE 1433
	25-100 mm	G	100 bar	07-3 marine type, gas-tight for gases and vapours, sealing EPDM	CE 1433
	25-100 mm	G	100 bar	08-3 marine type, gas-tight with limited disc leap for liquids, gases and vapours sealing EPDM	CE 1433
630		R			
	20-100 mm	E	40 bar	02-1 gas tight type for gases and vapours; sealing metal/metal	CE 0343
	20-100 mm	E	40 bar	04-1 type with limited disc leap for liquids, gases and vapours, sealing metal/metal	CE 1433
	20-40 mm	E	40 bar	52-1 type with extended seat, gas tight type for gases and vapours; sealing metal/metal	CE 1433
	20-50 mm	E	40 bar	54-1 type with extended seat gas-tight for liquids, sealing metal/metal	CE 1433

* for valves with an insert number of Notified Body 1433

Data given can be changed without notice.

Edition 01/2022

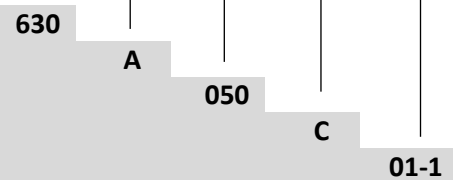
ORDERING

Figure	Body material	Nominal diameter	Nominal pressure	Type
630	A Grey cast iron EN-GJL-250	20-150 mm	C 16 bar	01-1 normal type for gases and vapours; sealing metal/metal

Order example by index

630 A 050 C 01-1

Full lift safety valve, flanged ends , angle form
 Grey cast iron EN-GJL-250
 Nominal diameter (mm)
 Nominal pressure PN 16
 Normal type for gases and vapours; sealing metal/metal



Data given can be changed without notice.

Edition 01/2022

STRAINERS zSTRA



Body material	Nominal pressure	Nominal diameter	Max. temperature
A Grey cast iron	A 6 bar	DN 15-200	300°C*
	C 16 bar	DN 15-400	300°C*
C Nodular cast iron	C 16 bar	DN 15-300	350°C*
	D 25 bar	DN 15-200	350°C*
F Cast steel	E 40 bar	DN 15-200	450°C
I Stainless steel	E 40 bar	DN 15-200	400°C

* for epoxy versions max. temperature 80 ° C



correspond to the pressure equipment directive 2014/68/UE marking CE for DN≥32

FEATURES

- screen made of stainless steel (from DN 50 with reinforced ring, from DN 150 with supporting basket)
- compact settlement
- environment-friendly
- cleaning of screen without disassembling
- face-to-face dimension according to EN 558 series 1
- flanges drilled according to EN 1092-1 for body material F, I
- flanges drilled according to EN 1092-2 for body material A,C
- closing tightness according to EN -12266-1

APPLICATION

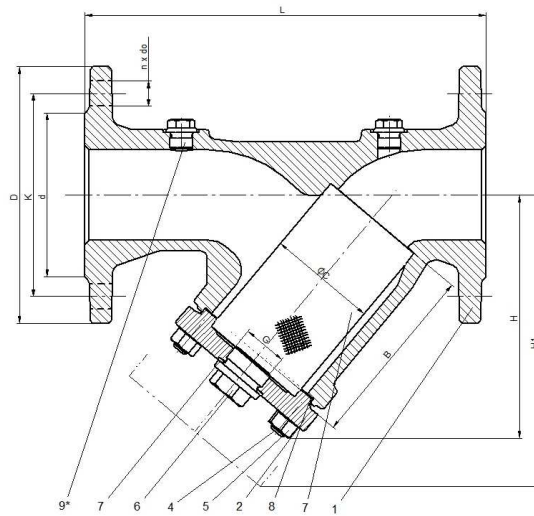
industries								
	INDUSTRY	SHIPBUILDING INDUSTRY	HEATING	POWER ENGINEERING				
	media							
		GLYCOL	INDUSTRIAL WATER	DIATHERMIC OIL	STEAM	COMPRESSED AIR	NEUTRAL FLUIDS	HYDROGEN

Data given can be changed without notice.

Edition 09/2023

FIG.821

MATERIALS, DIMENSIONS



Spare parts		Body material	A	C	F	I
	1	Body	EN- GJL- 250 5.1301 (ex.JL 1040)	EN-GJS-400-18-LT 5.3103 (ex.JS 1025)	GP240GH 1.0619	G-X5CrNiMo19-11-2 1.4408
	2	Cover	EN- GJL- 250 5.1301 (ex.JL 1040)	EN-GJS-400-18-LT 5.3103 (ex.JS 1025)	GP240GH 1.0619	G-X5CrNiMo19-11-2 1.4408
X	3	Screen	X5CrNi 18-10 1.4301			
	3.1	Supporting basket	X5CrNi 18-10 1.4301 for DN ≥ 150			
	4	Studs	5-6-A3A	A2-70	25CrMo4	A4-70
	5	Hexagon nut	5-A3A	A2-70	25CrMo4	A4-70
	6	Emptying screw	C35E			A2
	7	Plug gasket	A4 1.4571			
X	8	Cover gasket	CrNiSt – Graphite			
	9	Plug *,**	C35E			A2
	Max. temperature		300°C	350°C	450°C	400°C

* position of the plug don't refer to PN 6

** plugs on client's request

DN	15	20	25	32	40	50	65	80	100	125	150	200	250	300	350	400	
L (mm)	130	150	160	180	200	230	290	310	350	400	480	600	730	850	980	1100	
H (mm)	90	100	115	135	150	160	180	215	240	280	330	405	540	680	755	835	
H1 (mm)	135	160	180	215	240	250	285	330	395	455	525	650	870	1110	1250	1370	
G (cal)	3/8	3/8	3/4	3/4	1	1	1	1	1 1/2	1 1/2	1 1/2	1 1/2	1 1/2	1 1/2	1 1/2	1 1/2	
C (mm)	23	28	36	42	50	61,5	78,5	89,5	109,5	137,5	160	210	258	308	365	415	
B (mm)	56	68	82	98	114	119	134	149	169	199	224	284	434	555	640	695	
Weight (kg)																	
821	PN6	2,2	2,8	3,9	5,7	7,3	8,4	13,5	17,7	25,3	37,5	49,0	98,0	-	-	-	-
	PN16	2,6	3,0	4,3	6,8	9,0	11,0	14,6	18,6	27,0	38,5	54,5	110,0	165,0	285,0	373,0	540,0
	PN25	2,6	3,0	4,3	6,8	9,0	11,0	16,8	19,5	29,6	42,5	56,0	110,0	-	-	-	-
	PN40	2,7	3,6	4,5	6,3	8,7	11,0	18,5	23,5	33,0	54,0	75,0	137,0	-	-	-	-

Data given can be changed without notice.

Edition 09/2023

PRESSURE-TEMPERATURE RATINGS

Acc. EN 1092-2	PN				-10°C÷120°C	150°C	200°C	250°C	300°C	350°C	400°C	450°C
EN-GJL-250	6	bar	-----	---	6	5,4	4,8	4,2	3,6	---	---	---
	16		-----	---	16	14,4	12,8	11,2	9,6	---	---	---
EN-GJS-400-18 LT	16		-----	---	16	15,5	14,7	13,9	12,8	11,2	---	---
	25		-----	---	25	24,3	23	21,8	20	17,5	---	---
Acc. EN 1092-1			-40°÷<-10°C	-10°C÷50°C	100°C	150°C	200°C	250°C	300°C	350°C	400°C	450°C
GP240GH	40	bar	30	40	37,1	35,2	33,3	30,4	27,6	25,7	23,8	13,1
Acc. EN 1092-1				-60°÷<-10°C	-10°C÷100°C	150°C	200°C	250°C	300°C	350°C	400°C	450°C
G-X5CrNiMo19-11-2	40	bar		40	40	36,3	33,7	31,8	29,7	28,5	27,4	---

FLANGE DIMENSIONS ACC. PN-EN 1092-1/-2

DN		15	20	25	32	40	50	65	80	100	125	150	200	250	300	350	400
PN6	D (mm)	80	90	100	120	130	140	160	190	210	240	265	320	---	---	---	---
	K (mm)	55	65	75	90	100	110	130	150	170	200	225	280	---	---	---	---
	nxd (mm)	4x11	4x11	4x11	4x14	4x14	4x14	4x14	4x14	4x19	4x19	8x19	8x19	8x19	---	---	---
PN16	D (mm)	95	105	115	140	150	165	185	200	220	250	285	340	405	460	520	580
	K (mm)	65	75	85	100	110	125	145	160	180	210	240	295	355	410	470	525
	nxd (mm)	4x14	4x14	4x14	4x19	4x19	4x19	4x19	8x19	8x19	8x19	8x23	12x23	12x28	12x28	16x28	16x31
PN25	D (mm)	95	105	115	140	150	165	185	200	235	270	300	360	-----	-----	-----	-----
	K (mm)	65	75	85	100	110	125	145	160	190	220	250	310	-----	-----	-----	-----
	nxd (mm)	4x14	4x14	4x14	4x19	4x19	4x19	8x19	8x19	8x23	8x28	8x28	12x28	-----	-----	-----	-----
PN40	D (mm)	95	105	115	140	150	165	185	200	235	270	300	375	-----	-----	-----	-----
	K (mm)	65	75	85	100	110	125	145	160	190	220	250	320	-----	-----	-----	-----
	nxd (mm)	4x14	4x14	4x14	4x18	4x18	4x18	8x18	8x18	8x22	8x26	8x26	12x30	-----	-----	-----	-----

SCREENS

Screen	Type	DN	Mesh size	Mesh/cm2	Execution
Standard	F45	10-50	1,0	45	50
	F28	65-80	1,25	28	49
	F15	100-400	1,6	15	43
Other performance	screen cartridges F100 (0,6), F200 (0,5), F300 (0,4), F400 (0,32), F600 (0,25)				

* type with magnetic cartridge on client's request

Data given can be changed without notice.

Edition 09/2023

ZETKAMA Sp. z o.o.
Ul. 3 Maja 12
PL 57-410 Ścinawka Średnia

Tel. +48 74 8652 193
Tel. +48 74 8652 111
Fax +48 74 8652 199

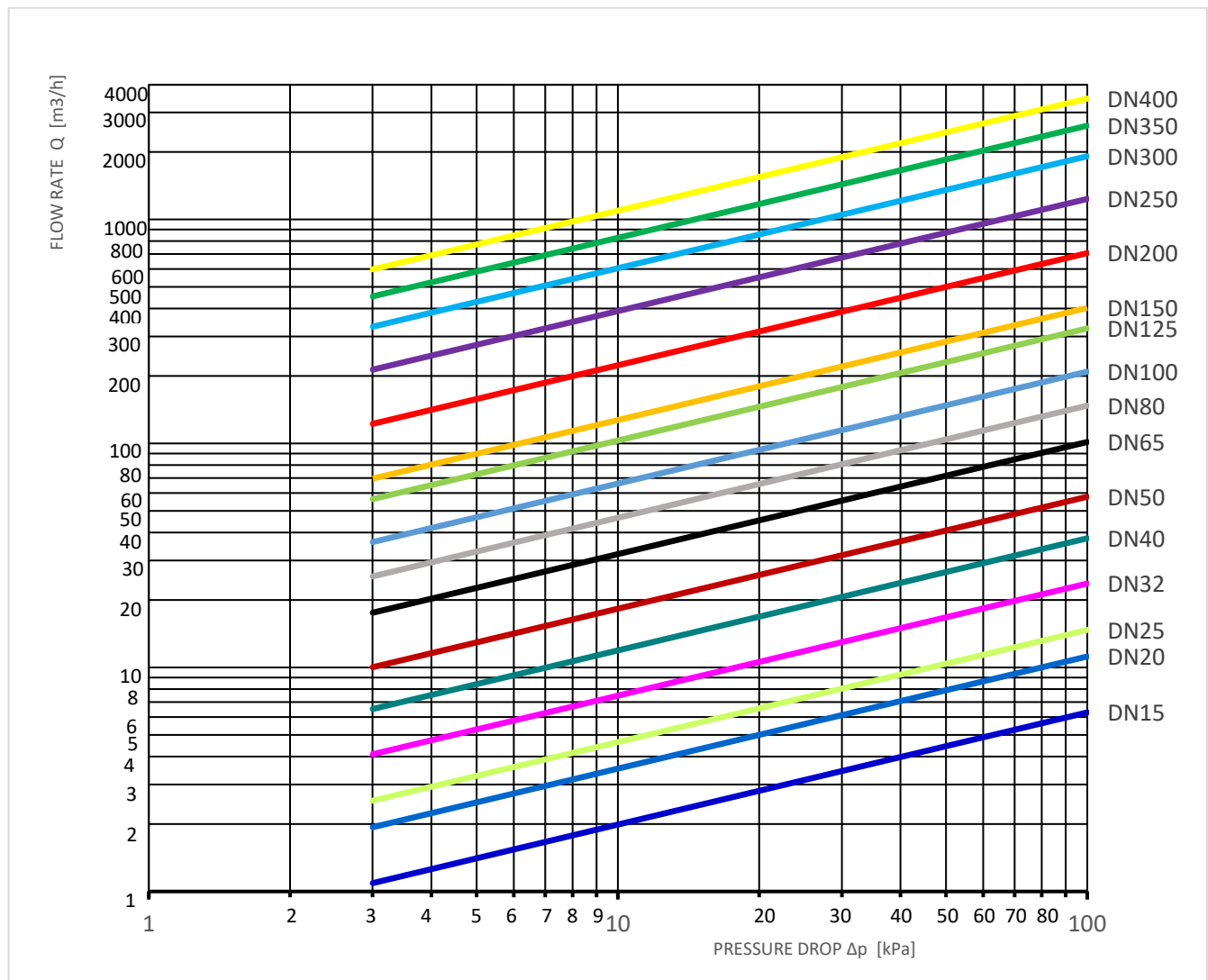
E-mail export@zetkama.com.pl
www.zetkama.com

FIG.821



HYDRAULIC CHARACTERISTIC

DN	15	20	25	32	40	50	65	80	100	125	150	200	250	300	350	400
Screen	Kv sr. [m ³ /h]															
Standard	6,3	11,2	14,7	23,7	37,7	57,9	101,5	147,4	209,6	326,2	403,0	707,0	1234,4	1916,2	2621,4	3460,3
F100 (0,63)	6,2	9,6	14,2	23,1	36,6	53,7	95,1	137,1	206,4	268,8	401,4	706,7	1229,4	1902,4	2611,0	3438,4
F200 (0,50)	6,2	9,5	14,1	23,0	35,6	53,0	92,7	133,4	202,7	314,3	462,3	811,0	1375,1	2133,1	2885,4	3747,0
F300 (0,40)	6,1	9,3	13,5	22,1	33,4	49,8	86,0	121,2	183,5	284,3	420,3	738,3	1274,3	2021,6	2698,8	3545,0
F400 (0,32)	6,0	9,1	13,2	21,7	33,4	48,5	82,9	115,9	173,7	268,8	401,4	706,7	1229,4	1902,4	2611,0	3438,4
F600 (0,25)	6,0	9,1	13,0	21,7	33,3	48,4	82,6	115,9	173,1	266,8	397,9	701,2	1225,0	1892,1	2606,8	3433,9



Data given can be changed without notice.

Edition 09/2023

ZETKAMA Sp. z o.o.
 Ul. 3 Maja 12
 PL 57-410 Ścinawka Średnia

Tel. +48 74 8652 193
 Tel. +48 74 8652 111
 Fax +48 74 8652 199

E-mail export@zetskama.com.pl
 www.zetskama.com

WZF-100 FILTER POLLUTION INDICATOR

WZF 100 - filter pollution indicator, operating on the principle of measuring pressure difference before and after the filter. The measurement is carried out by a magnetic field sensor that measures a displacement of a magnet placed on the sensor's piston.

The indicator is available in version with battery power supply and output and power supply from 4-20 mA current loop.

Display of the pollution status is carried out by means of a display made up of LEDs, two green ones, two orange ones and one red one. In addition, a blue LED indicates power on.

Sensor parameters

Ambient temperature from -20°C to 70°C

Medium temperature 120 °C

Medium - cold and hot water, neutral agents

Differential pressure measurement range from 0 bar to 1,2 bar

Maximum static pressure 16 bar

External and current loop power supply 16÷32 V DC

Degree of protection IP 66



WZF-100 FILTER POLLUTION INDICATOR

Remember that the direction of flow on the indicator and filter should be the same. To mount the indicator, order a filter drilled and plugged with G1/4" plugs.



The method of attachment on the filter.

Available accessories:

1. Allen tube for each DN diameter
2. zG1/4"/ wM10 x 1 reducer

More data in the user manual.

FIG.821



TYPE

Figure	Body material	Nominal diameter	Nominal pressure	Type
821	A Grey cast iron EN-GJL-250	15-50 mm	A 6 bar	mesh 1,00 mm, 45 mesh/cm ² 50
		65-80 mm	A 6 bar	mesh 1,25 mm, 28 mesh/cm ² 49
		100-200 mm	A 6 bar	mesh 1,60 mm, 15 mesh/cm ² 43
		15-200 mm	A 6 bar	mesh 0,63 mm, 100 mesh/cm ² 44
		15-200 mm	A 6 bar	mesh 0,50 mm, 200 mesh/cm ² 45
		15-200 mm	A 6 bar	mesh 0,40 mm, 300 mesh/cm ² 46
		15-200 mm	A 6 bar	mesh 0,32 mm, 400 mesh/cm ² 47
		15-200 mm	A 6 bar	mesh 0,25 mm, 600 mesh/cm ² 48
		15-50 mm	C 16 bar	mesh 1,00 mm, 45 mesh/cm ² 50
		65-80 mm	C 16 bar	mesh 1,25 mm, 28 mesh/cm ² 49
		100-400 mm	C 16 bar	mesh 1,60 mm, 15 mesh/cm ² 43
		15-400 mm	C 16 bar	mesh 0,63 mm, 100 mesh/cm ² 44
		15-400 mm	C 16 bar	mesh 0,50 mm, 200 mesh/cm ² 45
		15-400 mm	C 16 bar	mesh 0,40 mm, 300 mesh/cm ² 46
		15-400 mm	C 16 bar	mesh 0,32 mm, 400 mesh/cm ² 47
		15-400 mm	C 16 bar	mesh 0,25 mm, 600 mesh/cm ² 48
		15-50 mm	C 16 bar	mesh 1,00 mm, 45 mesh/cm ² , with magnetic cartridge 70
		65-80 mm	C 16 bar	mesh 1,25 mm, 28 mesh/cm ² , with magnetic cartridge 69
		100-400 mm	C 16 bar	mesh 1,60 mm, 15 mesh/cm ² , with magnetic cartridge 63
		15-50 mm	C 16 bar	mesh 1,00 mm, 45 mesh/cm ² , epoxy paint 50-D

Data given can be changed without notice.

Edition 09/2023

FIG.821



		65-80 mm	C 16 bar	mesh 1,25 mm, 28 mesh/cm ² , epoxy paint	49-D
		100-400 mm	C 16 bar	mesh 1,60 mm, 15 mesh/cm ² , epoxy paint	43-D
		15-400 mm	C 16 bar	mesh 0,63 mm, 100 mesh/cm ² , epoxy paint	44-D
		15-400 mm	C 16 bar	mesh 0,50 mm, 200 mesh/cm ² , epoxy paint	45-D
		15-400 mm	C 16 bar	mesh 0,40 mm, 300 mesh/cm ² , epoxy paint	46-D
		15-400 mm	C 16 bar	mesh 0,32 mm, 400 mesh/cm ² , epoxy paint	47-D
		15-400 mm	C 16 bar	mesh 0,25 mm, 600 mesh/cm ² , epoxy paint	48-D
821	C Nodular cast iron EN-GJS-400-18-LT	15-50 mm	C 16 bar	mesh 1,00 mm, 45 mesh/cm ²	50
		65-80 mm	C 16 bar	mesh 1,25 mm, 28 mesh/cm ²	49
		100-300 mm	C 16 bar	mesh 1,60 mm, 15 mesh/cm ²	43
		15-300 mm	C 16 bar	mesh 0,63 mm, 100 mesh/cm ²	44
		15-300 mm	C 16 bar	mesh 0,50 mm, 200 mesh/cm ²	45
		15-300 mm	C 16 bar	mesh 0,40 mm, 300 mesh/cm ²	46
		15-300 mm	C 16 bar	mesh 0,32 mm, 400 mesh/cm ²	47
		15-300 mm	C 16 bar	mesh 0,25 mm, 600 mesh/cm ²	48
		15-50 mm	D 25 bar	mesh 1,00 mm, 45 mesh/cm ²	50
		65-80 mm	D 25 bar	mesh 1,25 mm, 28 mesh/cm ²	49
		100-200 mm	D 25 bar	mesh 1,60 mm, 15 mesh/cm ²	43
		15-200 mm	D 25 bar	mesh 0,63 mm, 100 mesh/cm ²	44
		15-200 mm	D 25 bar	mesh 0,50 mm, 200 mesh/cm ²	45
		15-200 mm	D 25 bar	mesh 0,40 mm, 300 mesh/cm ²	46
		15-200 mm	D 25 bar	mesh 0,32 mm, 400 mesh/cm ²	47

Data given can be changed without notice.

Edition 09/2023

ZETKAMA Sp. z o.o.
Ul. 3 Maja 12
PL 57-410 Ścinawka Średnia

Tel. +48 74 8652 193
Tel. +48 74 8652 111
Fax +48 74 8652 199

E-mail export@zetkama.com.pl
www.zetkama.com

FIG.821



821	F Cast steel GP240GH	15-200 mm	D 25 bar	mesh 0,25 mm, 600 mesh/cm ²	48
		15-50 mm	E 40 bar	mesh 1,00 mm, 45 mesh/cm ²	50
		65-80 mm	E 40 bar	mesh 1,25 mm, 28 mesh/cm ²	49
		100-200 mm	E 40 bar	mesh 1,60 mm, 15 mesh/cm ²	43
		15-200 mm	E 40 bar	mesh 0,63 mm, 100 mesh/cm ²	44
		15-200 mm	E 40 bar	mesh 0,50 mm, 200 mesh/cm ²	45
		15-200 mm	E 40 bar	mesh 0,40 mm, 300 mesh/cm ²	46
		15-200 mm	E 40 bar	mesh 0,32 mm, 400 mesh/cm ²	47
		15-200 mm	E 40 bar	mesh 0,25 mm, 600 mesh/cm ²	48
821	I Stainless steel G-X5GNiMo19-11-2	15-50 mm	E 40 bar	mesh 1,00 mm, 45 mesh/cm ²	50
		65-80 mm	E 40 bar	mesh 1,25 mm, 28 mesh/cm ²	49
		100-200 mm	E 40 bar	mesh 1,60 mm, 15 mesh/cm ²	43
		15-200 mm	E 40 bar	mesh 0,63 mm, 100 mesh/cm ²	44
		15-200 mm	E 40 bar	mesh 0,50 mm, 200 mesh/cm ²	45
		15-200 mm	E 40 bar	mesh 0,40 mm, 300 mesh/cm ²	46
		15-200 mm	E 40 bar	mesh 0,32 mm, 400 mesh/cm ²	47
		15-200 mm	E 40 bar	mesh 0,25 mm, 600 mesh/cm ²	48
		15-50 mm	E 40 bar	mesh 1,00 mm, 45 mesh/cm ² , type for hydrogen	50-H
		65-80 mm	E 40 bar	mesh 1,25 mm, 28 mesh/cm ² , type for hydrogen	49-H
		100-200 mm	E 40 bar	mesh 1,60 mm, 15 mesh/cm ² , type for hydrogen	43-H
		15-200 mm	E 40 bar	mesh 0,63 mm, 100 mesh/cm ² , type for hydrogen	44-H
		15-200 mm	E 40 bar	mesh 0,50 mm, 200 mesh/cm ² , type for hydrogen	45-H

Data given can be changed without notice.

Edition 09/2023

ZETKAMA Sp. z o.o.
Ul. 3 Maja 12
PL 57-410 Ścinawka Średnia

Tel. +48 74 8652 193
Tel. +48 74 8652 111
Fax +48 74 8652 199

E-mail export@zetkama.com.pl
www.zetkama.com

FIG.821



15-200 mm	E 40 bar	46-H mesh 0,40 mm, 300 mesh/cm ² , type for hydrogen
15-200 mm	E 40 bar	47-H mesh 0,32 mm, 400 mesh/cm ² , type for hydrogen
15-200 mm	E 40 bar	48-H mesh 0,25 mm, 600 mesh/cm ² , type for hydrogen

ORDERING

Figure	Body material	Nominal diameter	Nominal pressure	Type
821	A Grey cast iron EN-GJL-250	15-50 mm	A 6 bar	50 mesh 1,00 mm, 45 mesh/cm ²

Order example acc. index

821 A 050 C 50

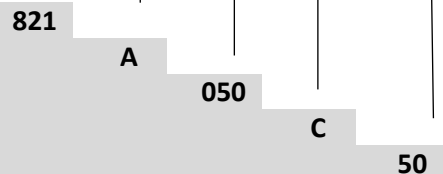
Strainer, ends flanged, form Y-tape

Grey cast iron EN-GJL-250

Nominal diameter (mm)

Nominal pressure PN 16

Mesh 1,00 mm, 45 mesh/cm²



Data given can be changed without notice.

Edition 09/2023

ZETKAMA Sp. z o.o.
Ul. 3 Maja 12
PL 57-410 Ścinawka Średnia

Tel. +48 74 8652 193
Tel. +48 74 8652 111
Fax +48 74 8652 199

E-mail export@zetkama.com.pl
www.zetkama.com