



www.ecivalve.it

Technical Valve Catalogue

Production of the
Best Quality
Range of Valves





BRONZE VALVES



BRASS VALVES



CAST-IRON VALVES

General Index

General Index	3
Bronze Valves	5
BR 118	6
BR 120	7
BR 220	8
BR 325	9
BR 432	10
BR 516	11
BR 520	12
BR 525	13
BR 582	14
BR 825	15
Valve Instalation Tips	16
Brass Valves	19
BS 135	20
BS 202	21
BS 302	22
BS 501	23
BS 502	24
BS 910	25
Cast-Iron Valves	27
G 101	28
G 103	29
G 201	30
G 203	31
G 301	32
G 303	33
G 311	34
G 401	35
G 403	36
G 501	37
G 503	38
G 505	39
G 507	40
G 801	41
Pressure Independent Control Valves (PICV)	43
BS 925 (PICV)	44
Valve Accessories	51
V1100/V1200	52
Certifications	53
Notes	54



European Casting Industry ECI is dedicated to manufacturing the best quality of wide range valves. Our goal is to provide first class quality and standards to our clients. ECI valves have a wide range of use in the heating, ventilating, and air-conditioning systems, while also being applicable in the oil and gas fields. Each of our products has been systematically tested and monitored to ensure that the standards of quality are being met.

ECI produces the same valves with different standards, this allow better distribution of valves to more areas around the world, particularly in the Middle East, Europe and North America.

Bronze Valves

BR 118	6
BR 120	7
BR 220	8
BR 325	9
BR 432	10
BR 516	11
BR 520	12
BR 525	13
BR 582	14
BR 825	15

BR 118

BRONZE BALL VALVE

WORKING PRESSURE PN 25

FULL BORE

TAPER PIPE THREADED TO ISO 7

DESIGN STANDARD GB/T8464



www.ecivalve.it

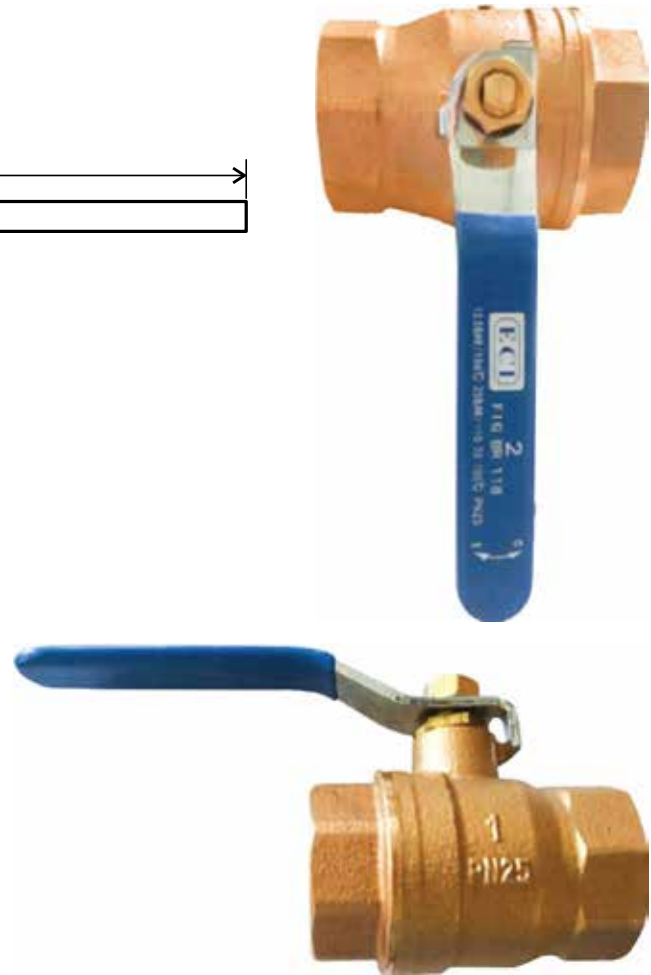
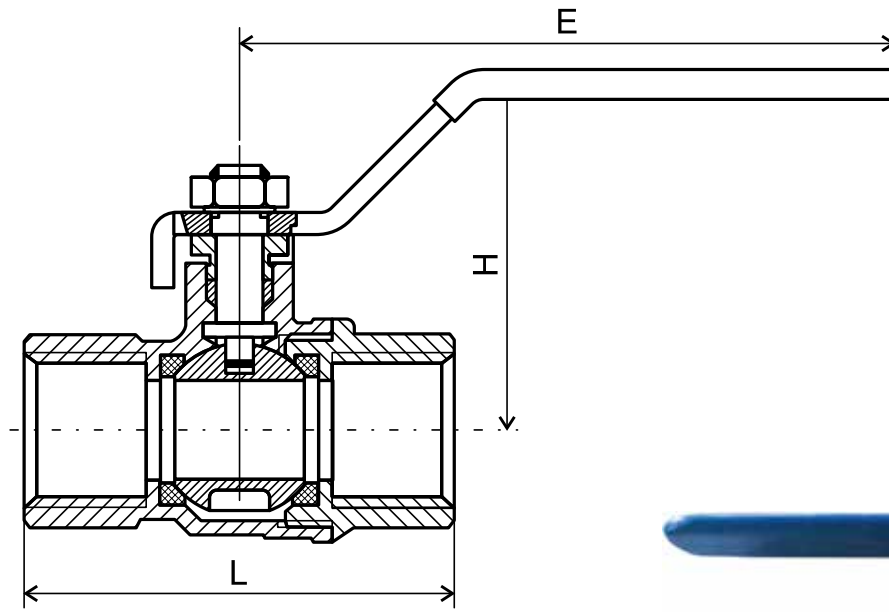

Specifications:

- WORKING PRESSURE: PN 25
- WORKING TEMPERATURE: $T \leq 170^{\circ}\text{C}$
- PORT SIZE:
- $\frac{1}{2}$ " UP TO 2"
- FULL PORT
- TESTING PRESSURE: 100 PSI AIR FOR SHELL & SEAT
- TAPER PIPE THREADED TO NPT AND ISO 7-1 (EX. BS-21)
- SUITABLE MEDIA: WATER, OIL, AIR, & STEAM

Dimensions (mm)

DN	SIZE INCH	L	H	E	Weight(KGS)
15	$\frac{1}{2}$ "	53	44	44	0.228
20	$\frac{3}{4}$ "	61	51	51	0.366
25	1"	71	55	55	0.539
32	$1\frac{1}{4}$ "	85	65	65	0.838
40	$1\frac{1}{2}$ "	92	70	70	1.133
50	2"	114	83	83	1.880

Materials

No.	DESCRIPTION	BRONZE
1	Seat retainer	Bronze CC491K
2	Packing	P.T.F.E
3	Seat	P.T.F.E
4	Ball	Brass CW617N
5	Body	Bronze CC491K
6	Stem	DZR Brass CW602N
7	Stem	P.T.F.E
8	Packing	P.T.F.E
9	Gland Nut	Brass CW617N
10	Lever	Mild Steel Chrome Plated
11	Lever	PVC
12	Washer	Stainless Steel
13	Nut	Stainless Steel



All data, descriptions and pictures contained in this leaflet may be subject to change without prior notice.

European Casting Industry Srl | Via Lazzaretto, 11 | 20124 Milan MI, Italia | P.Iva: 03228761205 | www.ecivalve.it | info@ecivalve.it

BR 120

BRONZE BALL VALVE

600 PSI / 41.4 BAR WOG

150 PSI / 10.3 BAR WSP

½"~1" FULL PORT

1¼"~4" CONVENTIONAL PORT

Conforms to MSS SP-110

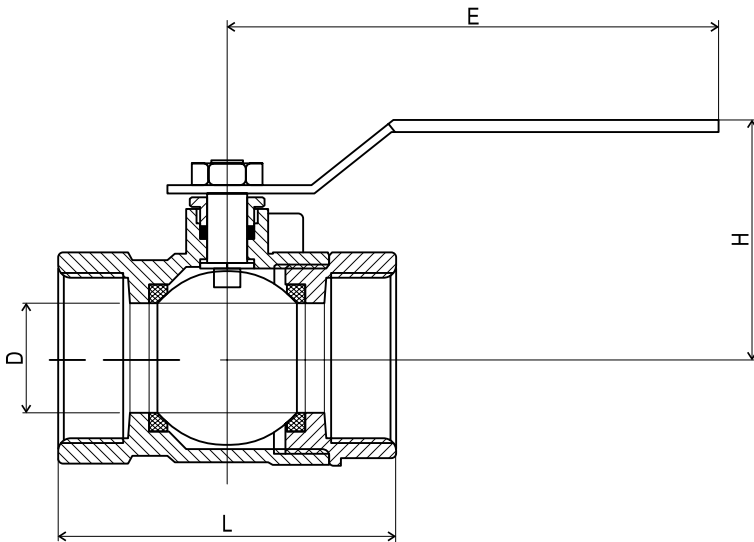

Specifications:

- WORKING PRESSURE:
600 PSI / 41.4 BAR WOG
150 PSI / 10.3 BAR WSP
- WORKING TEMPERATURE: $T \leq 140^{\circ}\text{C}$
- PORT SIZE:
½"~1" FULL PORT
1¼"~4" RED PORT (CONVENTIONAL)
- TESTING PRESSURE: 100 PSI AIR FOR SHELL & SEAT
- TAPER PIPE THREADED TO NPT AND ISO 7-1 (ex. BS-21)
- SUITABLE MEDIA: WATER, OIL, AIR & STEAM

Dimensions (mm)

DN	SIZE INCH	L	H	E	Weight(KGS)
15	½"	61	48	102	0,399
20	¾"	74	56	122	0,581
25	1"	86	65	122	0,889
32	1¼"	102	69	122	1.406
40	1½"	109	79	175	2.177
50	2"	117	84	175	3.039
65	2½"	150	91	175	3.856
80	3"	180	114	201	6.713



All data, descriptions and pictures contained in this leaflet may be subject to change without prior notice.

European Casting Industry Srl | Via Lazzaretto, 11 | 20124 Milan MI, Italia | P.Iva: 03228761205 | www.ecivalve.it | info@ecivalve.it



www.ecivalve.it

ECI EUROPEAN CASTING INDUSTRY

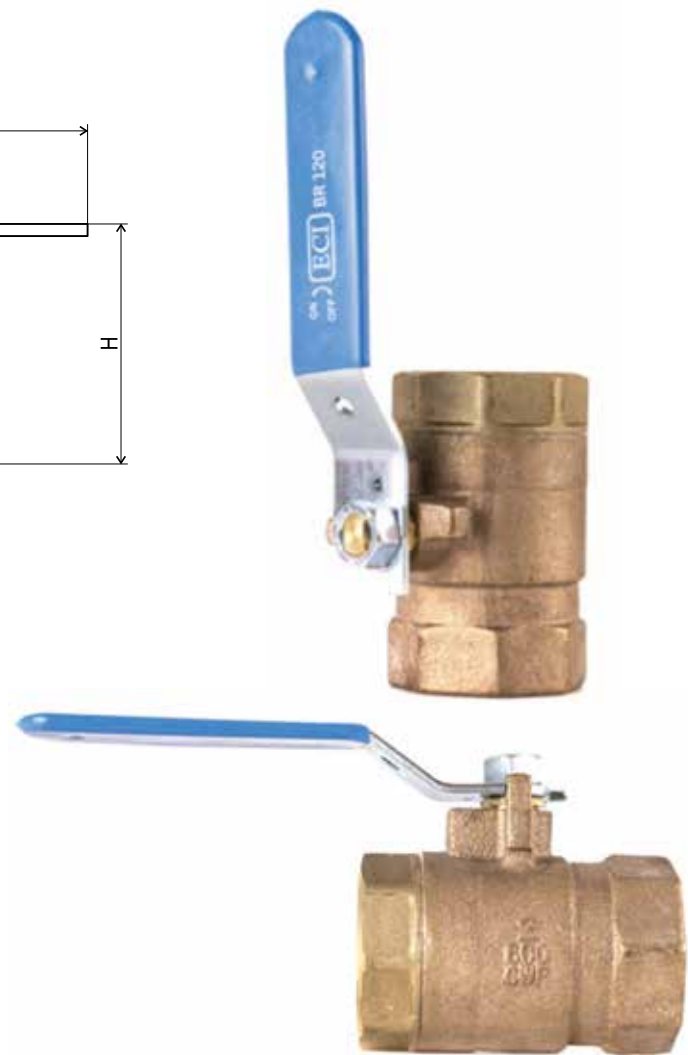

Materials

No.	DESCRIPTION	BRONZE	LEAD FREE
1	Body	ASTM B584 C84400	ASTM C89844
2	Tailpiece	ASTM B584 C84400	ASTM C89844
3	Ball	ASTM B16 C36000 or B124 C37700	Stainless Steel 316
4	Stem	ASTM B16 C36000	ASTM C46400
5	Packing Nut	ASTM B16 C36000	ASTM B16 C36000
6	Ball Seat	15% Glass RPTFE	TEFLON PTFE
7	Packing	TEFLON PTFE	TEFLON PTFE
8	Thrust Washer	TEFLON PTFE	TEFLON PTFE
9	Handle	Steel-Zn.P.	Steel-Zn.P.
10	Handle Sleeve	Vinyl	Vinyl
11	Handle Nut	Steel-Zn.P.	Steel-Zn.P.

BR 220

BRONZE STRAINER

PN 20 "Y" TYPE



www.ecivalve.it

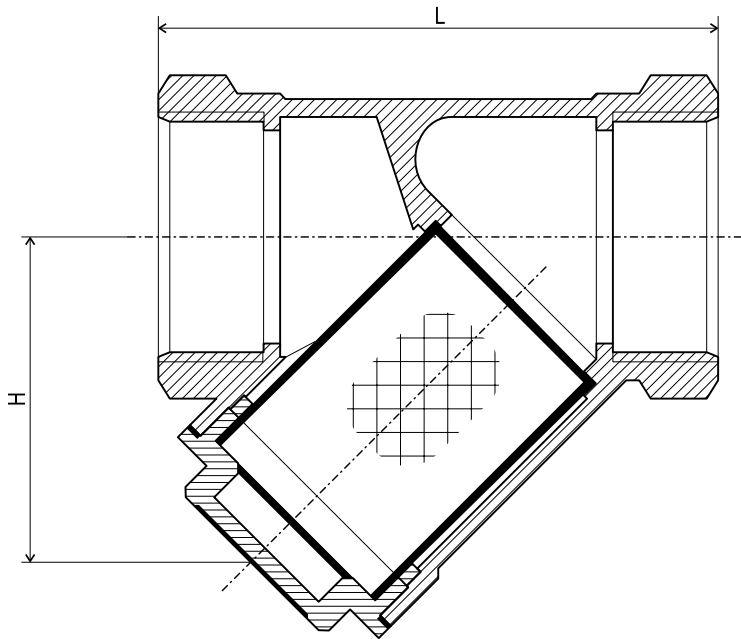

Specifications:

- PRESSURE RATING: PN20
- SUITABLE MEDIA: WATER, OIL, AIR & GAS
- WORKING TEMPERATURE: $T \leq 170^{\circ}\text{C}$
- TAPER PIPE THREAD TO NPT AND ISO 7-1 (EX. BS-21)

Dimensions (mm)

DN	SIZE INCH	L	H	Weight(KGS)
15	½"	58	33	0.185
20	¾"	70	41	0.298
25	1"	88	49	0.426
32	1¼"	96	56	0.720
40	1½"	107	62	0.980
50	2"	126	80	1.500

Materials

No.	DESCRIPTION	BRONZE
1	Body	Bronze CC491K
2	Screen	Stainless Steel Type 304
3	Gasket	P.T.F.E
4	Cap	Bronze CC491K



All data, descriptions and pictures contained in this leaflet may be subject to change without prior notice.

European Casting Industry Srl | Via Lazzaretto, 11 | 20124 Milan MI, Italia | P.Iva: 03228761205 | www.ecivalve.it | info@ecivalve.it

BR 325

BRONZE CHECK VALVE

PN 25 SWING TYPE

Conforms to MSS SP-80

www.ecivalve.it

ECI EUROPEAN
CASTING
INDUSTRY

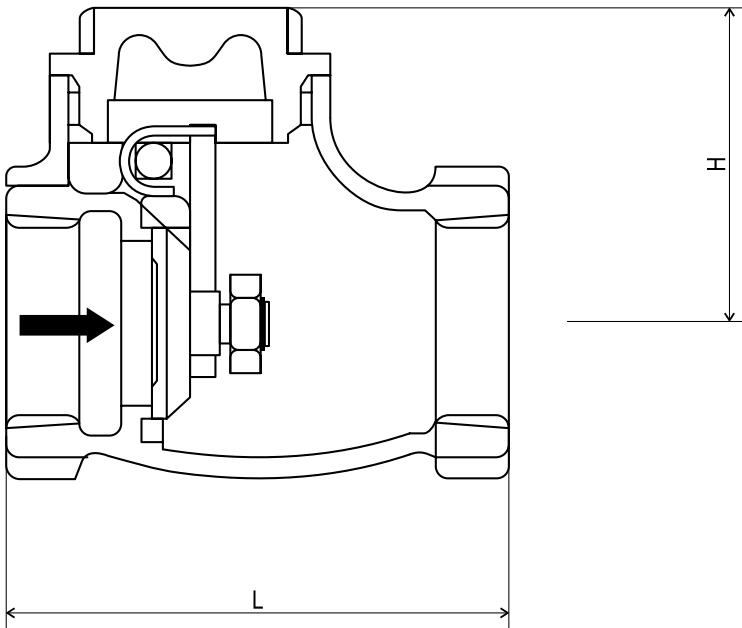

Specifications:

- PRESSURE RATING: PN25
- SUITABLE MEDIA: WATER, OIL, AIR & STEAM
- WORKING TEMPERATURE: $T \leq 170^{\circ}\text{C}$
- TAPER PIPE THREAD TO NPT AND ISO 7-1 (EX. BS-21)

Dimensions (mm)

DN	SIZE INCH	L	H	Weight(KGS)
10	3/8"	48	33	0.301
15	1/2"	58	38	0.332
20	3/4"	66	42	0.440
25	1"	80	49	0.687
32	1 1/4"	89	56	1.010
40	1 1/2"	95	65	1.423
50	2"	108	76	2.390

Materials

No.	DESCRIPTION	MATERIAL
1	Body	Bronze CC491K
2	Cap	Bronze CC491K
3	Disc	Bronze CC491K (1.1/4" - 2")
3	Disc	Brass CW617N (3/4" - 1")
4	Hinge	Bronze CC491K
5	Hinge Pin	Stainless Steel
6	Hinge Nut	Brass CW617N

BR 432

BRONZE GLOBE VALVE

PN 32

Rising stem

Conforms to BS 5154/MSS SP-80



www.ecivalve.it

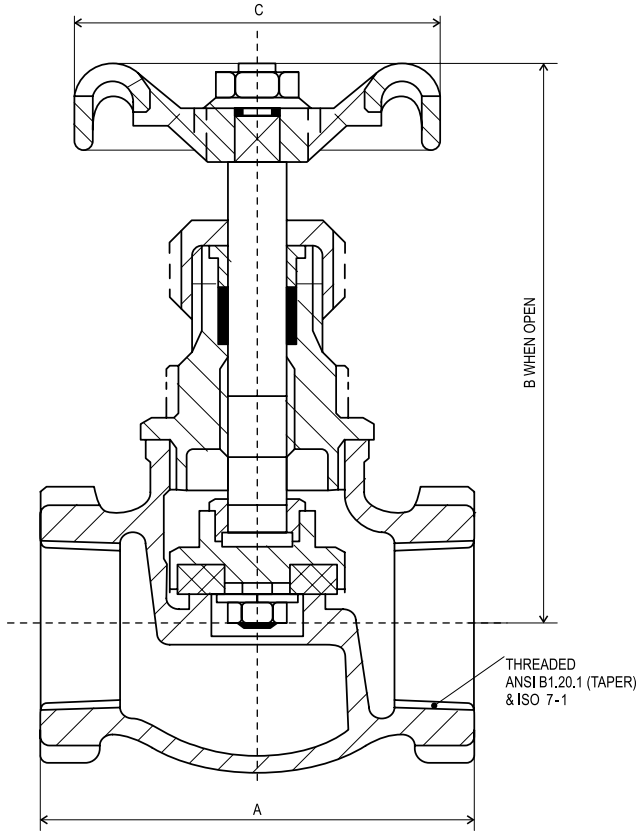

Specifications:

- PRESSURE RATING: PN32
- SUITABLE MEDIA: WATER, OIL, AIR & STEAM
- WORKING TEMPERATURE: $T \leq 180^{\circ}\text{C}$
- TAPER PIPE THREAD TO NPT AND ISO 7-1 (EX. BS-21)

Dimensions (mm)

DN	SIZE INCH	A	B	C	Weight(KGS)
15	½"	62	101	52	0.540
20	¾"	74	115	52	0.650
25	1"	90	125	70	0.810
32	1¼"	100	150	70	1.550
40	1½"	115	159	92	2.010
50	2"	136	191	103	3.080

Materials

No.	DESCRIPTION	MATERIAL
1	Body	Bronze CC491K
2	Bonnet	Bronze CC491K
3	Disc Stem Ring	Brass CW602N
4	Disc	P.T.F.E
5	Disc Holder	Bronze CC491K
6	Disc Nut	Brass CW602N
7	Washer	Brass CW602N
8	Stem	Brass CW602N
9	Gland	Brass CW614N
10	Packing	Asbestos Free
11	Packing Nut	Brass CW614N
12	Handwheel	Aluminum
13	Handwheel Nut	Brass CW614N
14	I.D Plate	Aluminum



All data, descriptions and pictures contained in this leaflet may be subject to change without prior notice.

European Casting Industry Srl | Via Lazzaretto, 11 | 20124 Milan MI, Italia | P.Iva: 03228761205 | www.ecivalve.it | info@ecivalve.it

BR 516

BRONZE GATE VALVE

PN16

Non-Rising stem

Conforms to PED 97/23/CE & it is CE marking-free as per art. 3 par.3

www.ecivalve.it

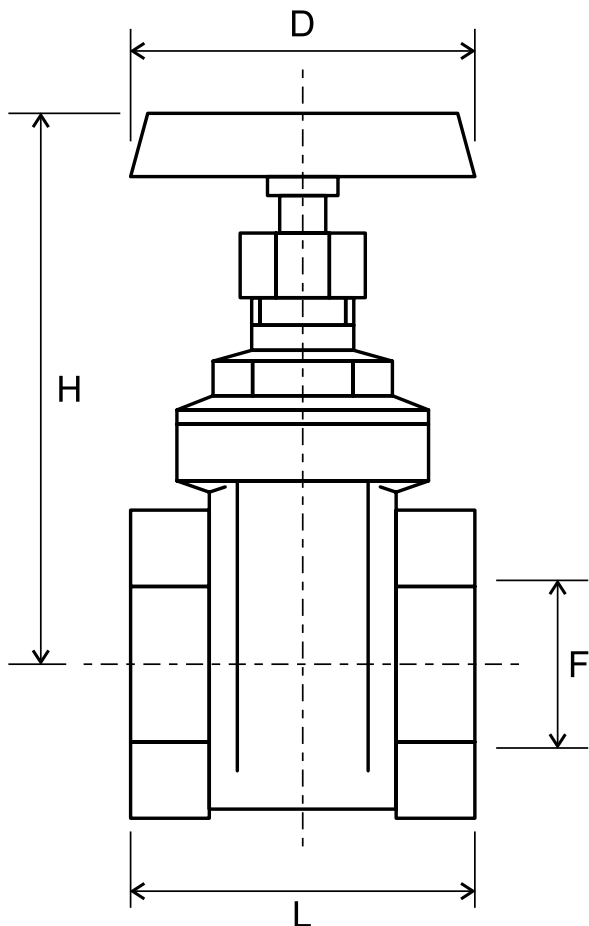

Specifications:

- PRESSURE RATING: PN16
- SUITABLE MEDIA: WATER, OIL & AIR
- WORKING TEMPERATURE: $T \leq 80^{\circ}\text{C}$
- TAPER PIPE THREAD TO NPT AND ISO 228/1

Dimensions (mm)

DN	SIZE INCH	F	L	H	D	Weight(KGS)
15	½"	15	38	68	45	0.195
20	¾"	19	45	78	50	0.280
25	1"	24	48	92	55	0.380
32	1¼"	32	51	108	60	0.600
40	1½"	37	58	125	70	0.830
50	2"	47	62	145	80	1.210

Materials

DESCRIPTION	MATERIAL
Body	Bronze SN 5 UNI-EN1982 DIN50930/6
Bonnet	Brass CW 617 N-UNI-EN12165
Stem	Brass CW 614 N-UNI-EN12164
Packing	EPDM90 DUTRAL
Wedge	Brass DELTA CS UNI-EN1982 CB 7535
Handwheel	Steel with blue plastic coating
Handwheel Nut	Steel Zinc plated



All data, descriptions and pictures contained in this leaflet may be subject to change without prior notice.

European Casting Industry Srl | Via Lazzaretto, 11 | 20124 Milan MI, Italia | P.Iva: 03228761205 | www.ecivalve.it | info@ecivalve.it

BR 520

BRONZE GATE VALVE

PN 20
Non-Rising stem
Conforms to BS 5154



www.ecivalve.it

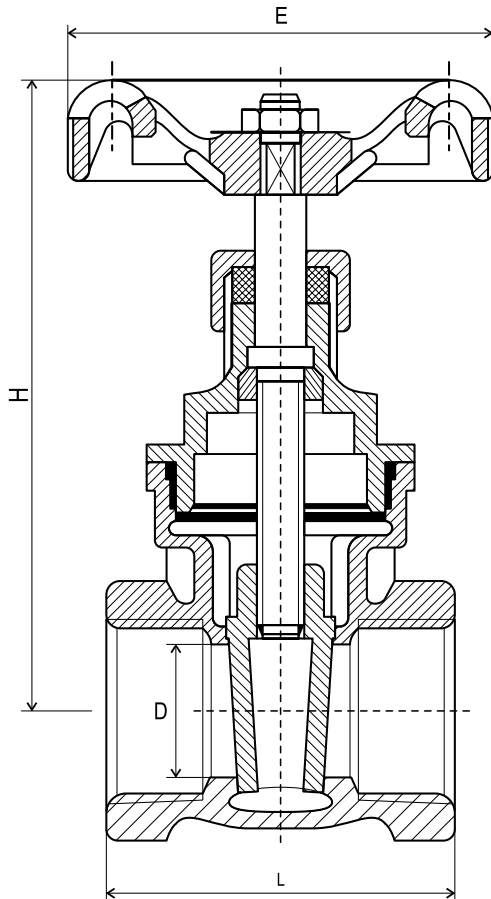

Specifications:

- PRESSURE RATING: PN20
- SUITABLE MEDIA: WATER, OIL, AIR & STEAM
- WORKING TEMPERATURE: $T \leq 170^{\circ}\text{C}$
- TAPER PIPE THREAD TO NPT AND ISO 7-1 (EX. BS-21)

Dimensions (mm)

DN	SIZE INCH	F	L	H	D	Weight(KGS)
15	½"	12.7	50	74	52	0.268
20	¾"	19.1	54	85	52	0.395
25	1"	25.4	62	106	70	0.585
32	1¼"	31.8	70	113	70	0.857
40	1½"	38.2	77	132	92	1.265
50	2"	50.9	87	155	92	1.900

Materials

No.	DESCRIPTION	MATERIAL
1	Body	Bronze CC491K
2	Bonnet	Bronze CC491K
3	Stem	DZR Brass CW602N
4	Packing Nut	Brass CW617N
5	Packing	P.T.F.E
6	Stem Bush	DZR Brass CW602N
7	Disc	Bronze CC491K
8	Handwheel	Aluminum
9	Handwheel Nut	Brass CW614N



All data, descriptions and pictures contained in this leaflet may be subject to change without prior notice.

European Casting Industry Srl | Via Lazzaretto, 11 | 20124 Milan MI, Italia | P.Iva: 03228761205 | www.ecivalve.it | info@ecivalve.it

BR 525

BRONZE GATE VALVE

PN 25

Non-Rising stem

Conforms to BS 5154/MSS SP-80



www.ecivalve.it

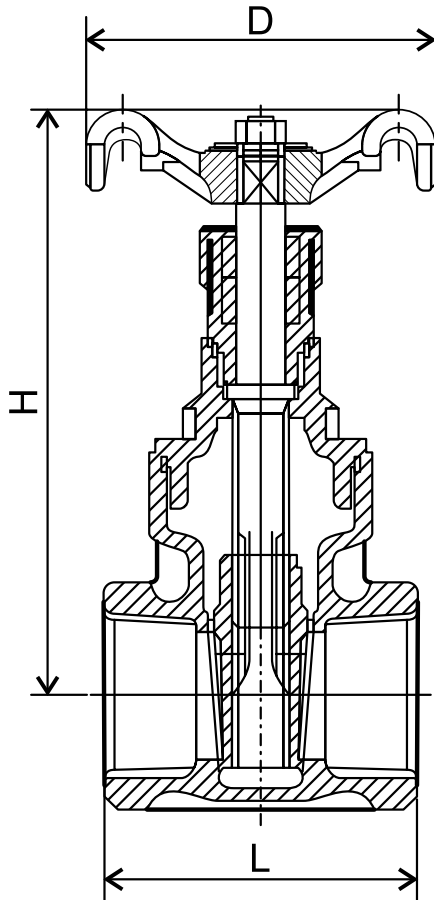

Specifications:

- PRESSURE RATING: PN25
- SUITABLE MEDIA: WATER, OIL, AIR & STEAM
- WORKING TEMPERATURE: $T \leq 170^{\circ}\text{C}$
- TAPER THREAD TO NPT AND ISO 7-1 (EX. BS-21)

Dimensions (mm)

DN	SIZE INCH	L	H	D	Weight(KGS)
8	¼"	46	75	45	0.284
10	⅜"	46	75	45	0.268
15	½"	51	82	52	0.341
20	¾"	55	95	65	0.582
25	1"	63	118	70	0.878
32	1¼"	71	144	79	1.360
40	1½"	73	166	92	1.750
50	2"	83	190	103	2.810

Materials

No.	DESCRIPTION	MATERIAL
1	Body	Bronze CC491K
2	Bonnet	Bronze CC491K
3	Stem	DZR Brass CW602N
4	Disc	Bronze CC491K
5	Stuffing Box	DZR Brass CW602N
6	Packing Ring	P.T.F.E
7	Gland	Brass CW614N
8	Packing Nut	Brass CW614N
9	Handwheel	Aluminum
10	Identification Plate	Aluminum
11	Handwheel Nut	Brass CW614N



All data, descriptions and pictures contained in this leaflet may be subject to change without prior notice.

European Casting Industry Srl | Via Lazzaretto, 11 | 20124 Milan MI, Italia | P.Iva: 03228761205 | www.ecivalve.it | info@ecivalve.it

BR 582

BRONZE GATE VALVE

PN 32

Rising stem

Conforms to BS 5154/MSS SP-80

www.ecivalve.it

ECI EUROPEAN
CASTING
INDUSTRY

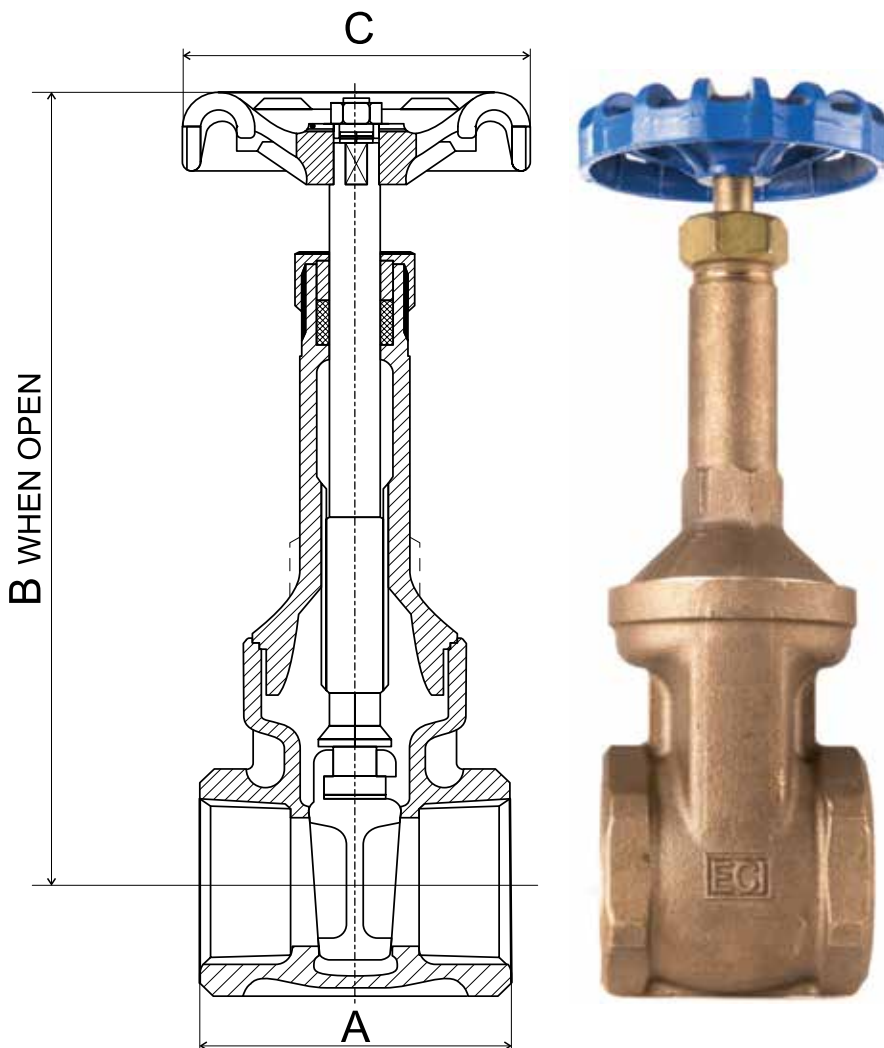

Materials

No.	DESCRIPTION	MATERIAL
1	Body	Bronze CC491K
2	Bonnet	Bronze CC491K
3	Stem	Bronze CC491K
4	Disc	Bronze CC491K
5	Packing	P.T.F.E
6	Clamping Ring	Brass CW614N
7	Packing Nut	Brass CW614N
8	Handwheel	Aluminum
9	Id Plate	Aluminum
10	Handwheel Nut	Brass CW614N

Dimensions (mm)

DN	SIZE INCH	A	B	C	Weight(KGS)
8	¼"	46	126	45	0.320
10	⅜"	46	126	45	0.310
15	½"	51	129	52	0.400
20	¾"	55	159	65	0.643
25	1"	63	189	70	0.998
32	1¼"	72	219	78	1.519
40	1½"	73	246	92	2.064
50	2"	83	301	92	3.191
65	2½"	108	369	134	5.800
80	3"	117	416	134	8.520

Specifications:

- PRESSURE RATING: PN32
- SUITABLE MEDIA: WATER, OIL, AIR & STEAM
- WORKING TEMPERATURE: T ≤ 170°C
- TAPER PIPE THREAD TO NPT AND ISO 7-1 (EX. BS-21)

ECI EUROPEAN
CASTING
INDUSTRY

All data, descriptions and pictures contained in this leaflet may be subject to change without prior notice.

European Casting Industry Srl | Via Lazzaretto, 11 | 20124 Milan MI, Italia | P.Iva: 03228761205 | www.ecivalve.it | info@ecivalve.it

BR 825

BRONZE FIXED ORIFICE
DOUBLE REGULATING VALVE (DRV)
PN 25
Conforms to BS7350



www.ecivalve.it

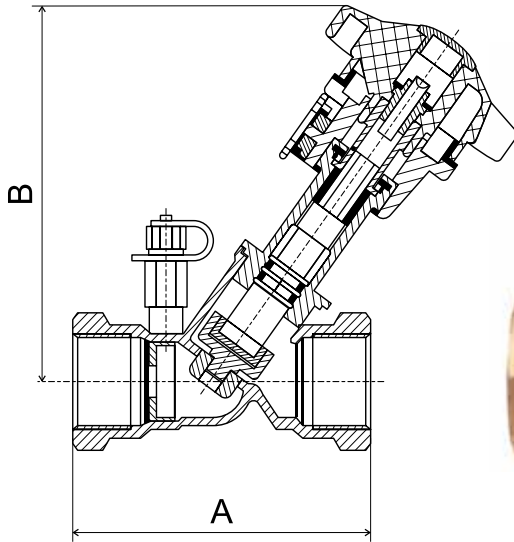

Specifications:

- PRESSURE RATING: PN25
- SUITABLE MEDIUM: WATER
- WORKING TEMPERATURE: $T \leq 120^{\circ}\text{C}$
- TAPER PIPE THREAD TO ISO 7-1 (EX. BS-21)
- Y-PATTERN GLOBE VALVE WITH THROTTLING DISC
- DRV WITH A FIXED ORIFICE DESIGN
- ACCURACY $\pm 5\%$ ON ALL SETTINGS
- DRV ALLOWS VALVE OPENING TO BE SET WITH ALLEN KEY.
- DRV HAS A MICROSET HAND WHEEL
- FOR USE IN HVAC & PLUMBING SYSTEMS
- TO BE USED FOR ISOLATING & TO BE RE-OPENED TO ITS PRE-SET POSITION
- SUPPLIED WITH TWO TEST POINTS
- DESIGN AND MANUFACTURE CONFORM TO BS7350

Dimensions (mm) & Coefficients

DN	SIZE INCH	A	B	FLOW (KV)	KVS	Weight(KGS)
15	½"	87	105	1.72	2.2	0.580
20	¾"	96	106	2.97	4.6	0.650
25	1"	100	127	4.75	8.5	0.890
32	1¼"	114	128	10.25	16.7	1.110
40	1½"	125	143	16.83	26.1	1.460
50	2"	146	144	27.26	43.2	1.980

Materials

No.	DESCRIPTION	MATERIAL	SIZES
1	Body	Bronze CC491K	All
2	Disc Face	P.T.F.E	1"-2"
2	Disc Face	DZR Brass CW602N	½"-¾"
3	Orifice Plate	DZR Brass CW602N	All
4	Nut	DZR Brass CW602N	All
5	Disc	DZR Brass CW602N	All
6	Disc Retaining Ring	DZR Brass CW602N	All
7	O Ring	N.B.R	All
8	Bonnet	DZR Brass CW602N	½"-1¼"
8	Bonnet	Bronze CC491K	1½"-2"
9	Stem	DZR Brass CW602N	All
10	Retainer Ring	Stainless Steel 304	All
11	Sleeve	Brass CW617N	All
12	Screw	Brass CW614N	All
13	Handwheel	PA	All
14	Cap	PA	All
15	Screw	Stainless Steel 304	All
16	Test Points	DZR Brass CW602N	All



All data, descriptions and pictures contained in this leaflet may be subject to change without prior notice.

European Casting Industry Srl | Via Lazzaretto, 11 | 20124 Milan MI, Italia | P.Iva: 03228761205 | www.ecivalve.it | info@ecivalve.it

Valve Instalation Tips

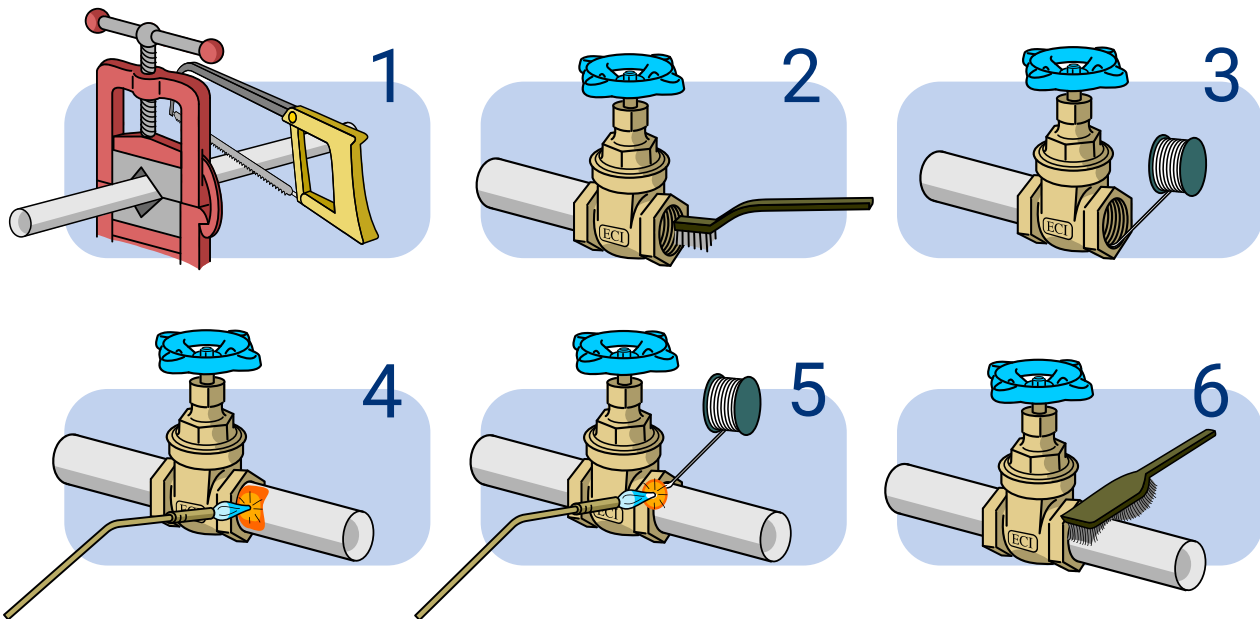

Soldering and Silver Brazing

The most important thing to consider is choosing the correct valve best suited for the application needed. Soldering and silver brazing is the most common method to joining the Bronze valves to tubes or fittings. Poor quality installation can lead to poor and damaged joints. This will lead to leakage and the damaging of the valve.

Perform the following steps to ensure a proper installation:

1 Start by cutting the tube end square, use either a tube cutter or a hack saw. Ream, burr and size the tube according to valve size.

2 Clean both ends of the cut tube, use a sand cloth or steel wire brush or even a nylon abrasive pad. It is important to eliminate all oxides and any soil from the tube ends to ensure a clean flow through the tubes.

3 Apply flux on the outside of the tube ends and the inside of the solder cups. It is best to use a soldering flux that can dissolve and remove any remaining drops of oxide and surface soil from the cleaned surfaces to be joined. It is important that the surface that will be joined to be completely covered in a thin layer of flux.

4 Make sure the valve is fully open. Start by applying heat to the tube ends first. Use the tube then to transfer the heat to the valve ends.

When using the Silver Brazing Method assemble the part to be brazed. Assemble the tube with the valve ends so that they are joined. It should be noted that the assembly should be firmly supported, and that there can be no change in alignment once the brazing operations starts. Apply flame using a torch to the valve ends. Heat uniformly around the end, moving from valve end to the tube end. Perform heating until noise from heating the flux is gone. For valves that are one-inch and larger it is difficult to raise the temperature around the entire joint to the same temperature. It

is recommended to use a double tip torch to allow a uniform temperature around a larger area. A desirable method is using an oxy-acetylene flame. Make sure that the flame is at least 1 inch away from the valve end. Apply heat uniformly on to the valve. Make sure the flame does not remain on any one point. Overheating the valve ends can lead to a damaged valve.

5 For the wire use a ½" solder for a ½" valve, increase wire size as the size of the valve increases. Excess use of solder can go through the tube and clog the sealing area. A constant run of solder or brazing alloy will be present when the joint is filled.

When using the Silver Brazing Method feed the brazing alloy into the joint between the tube and the fitting. Add the brazing only when the metals are heated to brazing temperatures. The flame can be moved away from the valve and tube end when the brazing alloy is applied. Move the flame back and forth as the alloy is inserted into the joint. The brazing alloy will diffuse readily into space between tube outer wall and valve socket. After the joint area is filled a continuous rim of brazing alloy will be visible.

6 Any flux residue or excess solder should be brushed off. A fillet should be visible around the valve end as it cools.

Silver Brazing Tips

Using different types of brazing materials does not affect how strong the brazing joint is. The strength of the joint depends a lot on the procedure. If the brazing alloy is applied correctly on the outside tube and the valve socket, then the joint will hold.

Threading Connection Tips

Any type of dirt, residue, or soil that go into the valve can highly damage parts of the valve and hinder its effectiveness. When using a threaded pipe connection, clean the threaded area to remove any deposits from it. Use air or steam to thoroughly remove any residue. Applying steam or air through the valve is also a good way to remove unwanted residue that can damage the valve.

Before installation, check line of flow through valve so that valve will function properly. Close valve completely before installation. Apply wrench to hex next to pipe and guard against possible distortion. After installation of valve, support line; a sagging pipe line can distort valve and cause failure.

Flanged Connection Tips

There are several steps to follow to make sure that a flanged joint will be properly assembled. First, clean the joint carefully. Then loosely assemble the joint by putting in the bottom two or three bolts. Then carefully insert the gasket into place. The bottom bolts will help locate the gasket and hold it in position. Then insert the rest of the bolts into place and tighten all of the bolts evenly—not in rotation, but by the cross-over method to load the bolts evenly and eliminate concentrated stresses. The bolts should be checked for tightness after an appropriate interval of use and retightened if necessary.



Brass Valves

BS 135	20
BS 202	21
BS 302	22
BS 501	23
BS 502	24
BS 910	25

BS 135

BRONZE BALL VALVE



www.ecivalve.it

ECI EUROPEAN
CASTING
INDUSTRY

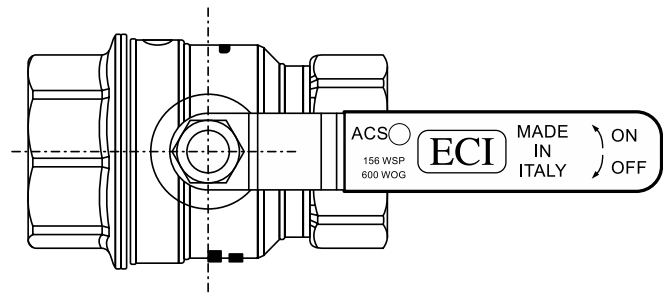
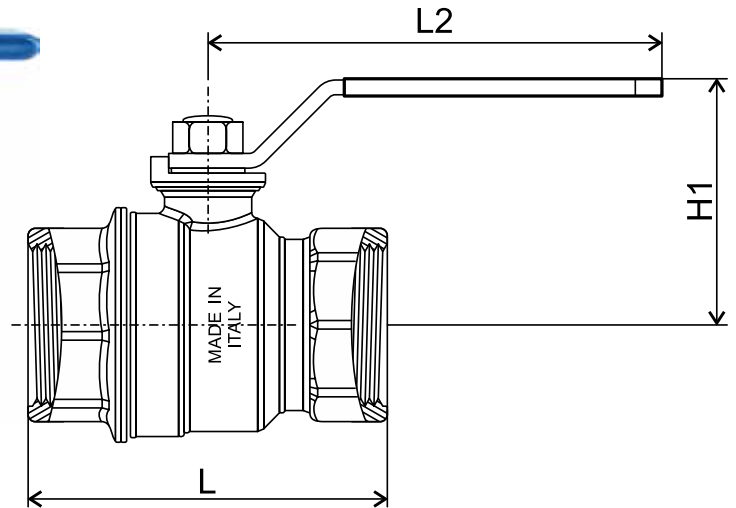

Specifications:

- FULL BORE SIZES 1/2" TO 2"
- STANDARD PASSAGE SIZES 2.1/2" UP TO 4"
- WP: 35 BAR SIZES 1/2" & 3/4" 28 BAR SIZES 1" UP TO 4"
- WORKING TEMPERATURE: T ≤ 140°C
- SUITABLE FOR WATER, GLYCOLATE SOLUTION (GLYCOL 50%)
NON DANGEROUS GAS
- THREADED ACCORDING TO ISO 228/1
- SHELL TEST ACCORDING TO UNI EN 13828

Dimensions (mm)

DN	SIZE INCH	L	H1	L2	Weight(KGS)
15	1/2"	53	35	77	0.177
20	3/4"	60	47	95	0.274
25	1"	74	51	95	0.407
32	1 1/4"	84	56	95	0.565
40	1 1/2"	95	69	137	0.984
50	2"	109	77	137	1.539
65	2 1/2"	146	102	173	2.980
80	3"	160	109	173	4.172
100	4"	207	200	187	7.004

Materials

DESCRIPTION	MATERIAL
Body	Brass chrome plated CW617N EN 12165
Tailpiece	Brass chrome plated CW614N EN 12164
Ball	Brass chrome plated CW617N EN 12165
Stem	Brass chrome plated CW614N EN 12164
Ball Seat	PTFE
Packing	PTFE
Handle	Galvanized steel
Handle Sleeve	Vinyl
Handle Nut	Galvanized steel



All data, descriptions and pictures contained in this leaflet may be subject to change without prior notice.

European Casting Industry Srl | Via Lazzaretto, 11 | 20124 Milan MI, Italia | P.Iva: 03228761205 | www.ecivalve.it | info@ecivalve.it

BS 202

BRASS STRAINER "Y" TYPE

According to PED 97/23/CE and it is CE marking-free as per art. 3 par. 3

www.ecivalve.it

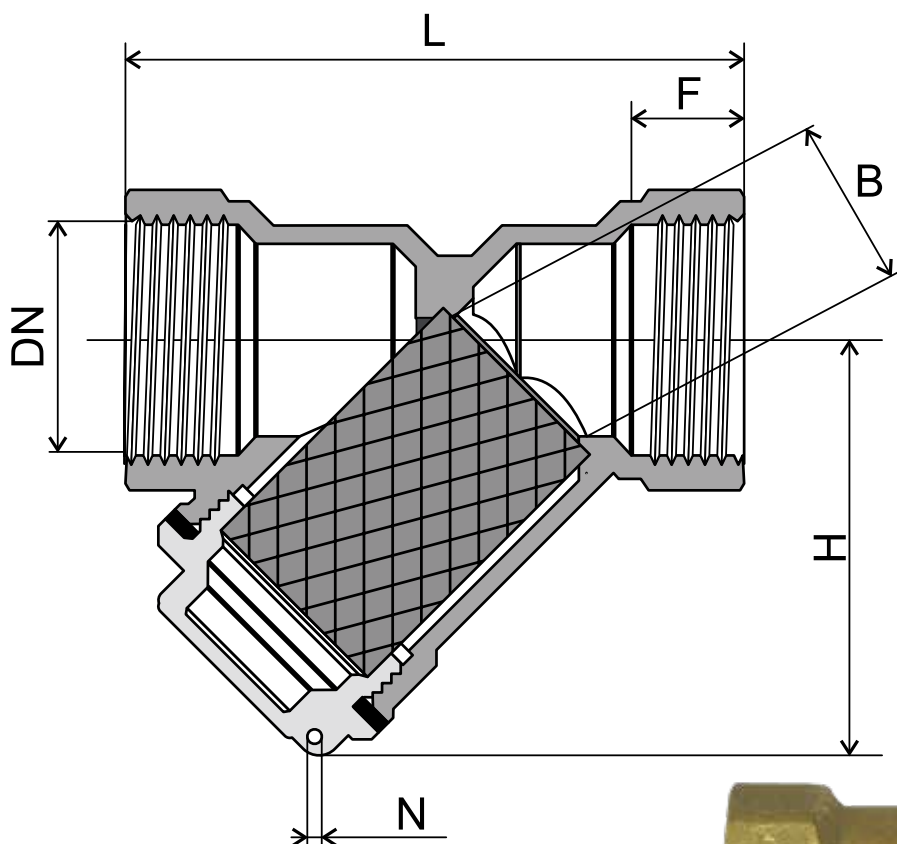

Specifications:

- WORKING PRESSURE: PN16
- WORKING TEMPERATURE: 0°C +100°C
- THREADED ACCORDING TO ISO 228/1 FXF
- SUITABLE MEDIA: WATER, OIL & AIR

Dimensions (mm)

DN	Size (Inch)	L	H	F	N	B	Weight KGS
15	1/2"	56	40	11	2	15	0,14
20	3/4"	67	46	11	2	18	0,18
25	1"	74	50	14	2	20	0,31
32	1.1/4"	96	67	15	2	31	0,50
40	1.1/2"	104	74	15	2	37	0,73
50	2"	125	90	18	2	44	1,19
65	2.1/2"	146	107	19	3	58	2,17
80	3"	170	123	21	3	70	2,70
100	4"	210	152	25	3	85	6,40



Materials

Description	Material
Body	Brass CW617N UNI-EN 12165
Screen	Stainless Steel AISI 304
Gasket	PTFE
Cap	Brass CW617N UNI-EN 12165



All data, descriptions and pictures contained in this leaflet may be subject to change without prior notice.

European Casting Industry Srl | Via Lazzaretto, 11 | 20124 Milan MI, Italia | P.Iva: 03228761205 | www.ecivalve.it | info@ecivalve.it

BS 302

BRASS CHECK VALVE
SWING TYPE

www.ecivalve.it

ECI EUROPEAN
CASTING
INDUSTRY

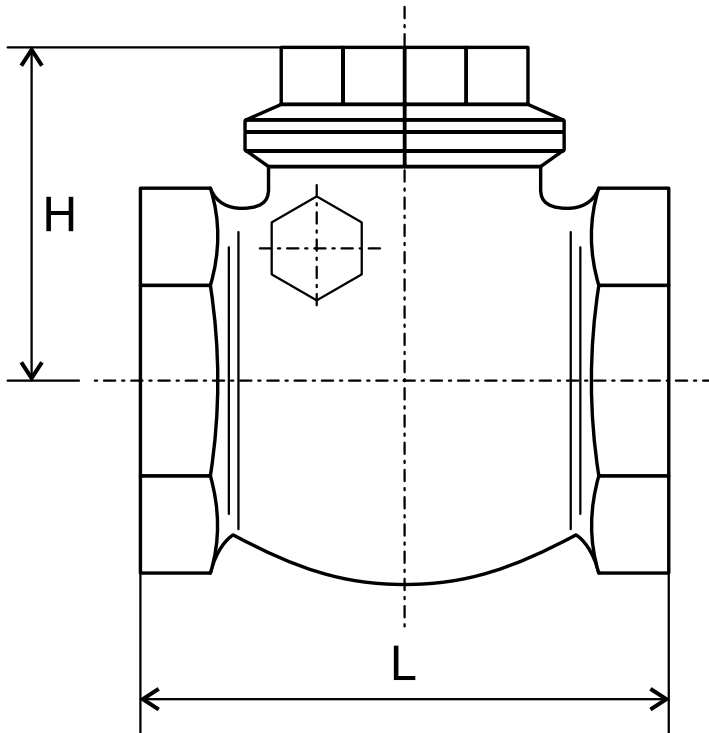

Dimensions (mm)

DN	SIZE INCH	L	H	F	B	Weight(KGS)
15	1/2"	47	51	8	15	0,16
20	3/4"	53	58	8	20	0,20
25	1"	63	68	10	25	0,35
32	1.1/4"	70	78	10	33	0,42
40	1.1/2"	88	98	10	37	0,76
50	2"	97	109	11	47	1,00
65	2.1/2"	120	130	16	55	1,65
80	3"	135	145	16	70	2,30
100	4"	162	180	20	90	5,10

Specifications:

- WORKING PRESSURE: PN 16
- WORKING TEMPERATURE: 0°C + 90°C
- METAL SEAT
- THREADING ACCORDING TO ISO 228/1
- SUITABLE FOR WATER, OIL & AIR

Materials

DESCRIPTION	MATERIAL
Body	CW 617N - UNI-EN 12165/98
Disc	CW 617N - UNI-EN 12165/98
Disc Gasket	NBR
Cap Gasket	Heat resisting fiber
Cap	CW 617N - UNI-EN 12165/98

ECI EUROPEAN
CASTING
INDUSTRY

All data, descriptions and pictures contained in this leaflet may be subject to change without prior notice.

European Casting Industry Srl | Via Lazzaretto, 11 | 20124 Milan MI, Italia | P.Iva: 03228761205 | www.ecivalve.it | info@ecivalve.it

BS 501

BRASS GATE VALVE

PN 16

Non-Rising stem - FXF

www.ecivalve.it

ECI EUROPEAN
CASTING
INDUSTRY

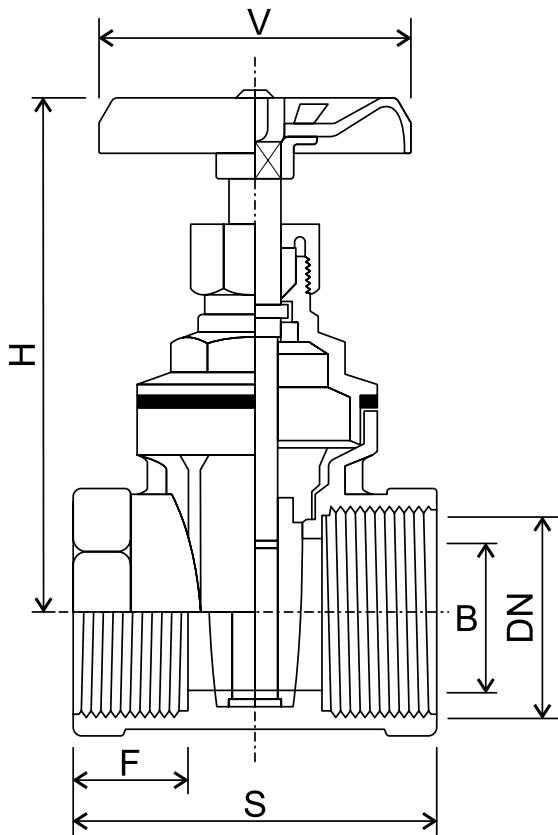

Specifications:

- PRESSURE RATING: PN16
- SUITABLE MEDIA: WATER, OIL & AIR
- WORKING TEMPERATURE: 0°C + 90°C
- ISO 288/1 THREAD FXF

Dimensions (mm)

DN	SIZE INCH	B	F	S	H	V	Weight(KGS)
15	1/2"	15	10	38	69	50	0,19
20	3/4"	19	11	44	77	50	0,26
25	1"	24	12	48	90	60	0,37
32	1.1/4"	32	13	51	97	60	0,53
40	1.1/2"	37	14	58	108	70	0,71
50	2"	47	15	63	131	80	1,16
65	2.1/2"	60	15	64	155	90	1,70
80	3"	72	18	75	183	100	2,47
100	4"	93	19	85	225	120	4,50

Materials

DESCRIPTION	MATERIAL
Body	CW617N - UNI EN 12165/98
Bonnet	CW617N - UNI EN 12165/98
Bonnet gasket	Heat resisting fiber
Stem	CW614N - UNI EN 12164/98
Wedge	CW617N - UNI EN 12165/98
Screwed ring	CW614N - UNI EN 12164/98
Packing	PTFE
Packing nut	CW614N - UNI EN 12164/98
Handwheel	Steel blue paint
Nut	Steel zinc plated

BS 502

BRASS GATE VALVE

PN 20

Non-Rising stem

Conforms to PED 97/23/CE & it is CE marking-free as per art. 3 par. 3

www.ecivalve.it

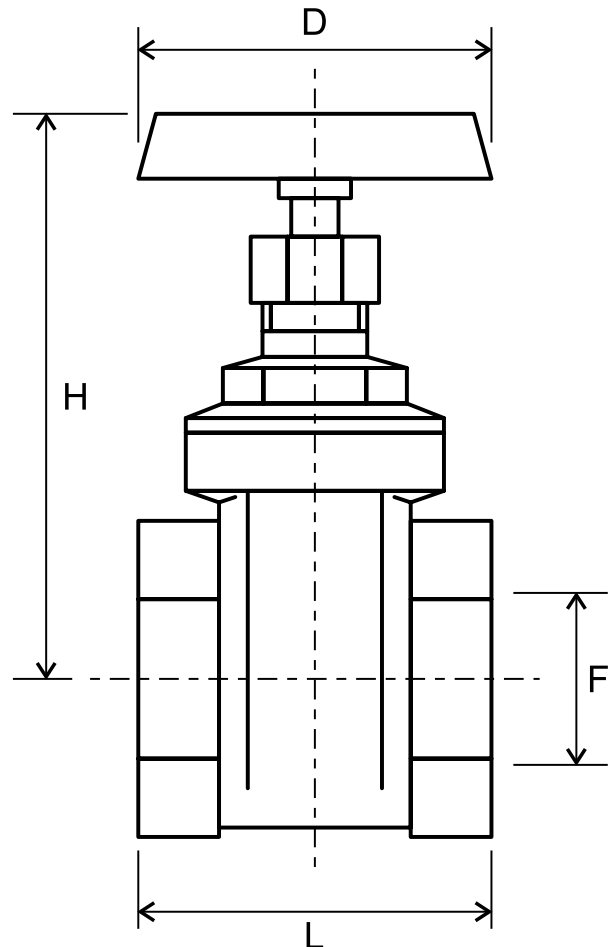

Specifications:

- PRESSURE RATING: PN20
- SUITABLE MEDIA: WATER, OIL & AIR
- WORKING TEMPERATURE: T ≤ 80°C
- TAPER PIPE THREAD TO NPT AND ISO 228/1

Dimensions (mm)

DN	SIZE INCH	F	L	H	D	Weight(KGS)
15	½"	15	43	68	45	0.200
20	¾"	19	47	78	50	0.290
25	1"	24	53	92	55	0.400
32	1¼"	32	57	108	60	0.620
40	1½"	37	61	125	70	0.750
50	2"	47	67	143	80	1.240
65	2½"	60	74	175	100	1.900
80	3"	72	86	205	100	2.560
100	4"	93	98	235	120	4.640

Materials

DESCRIPTION	MATERIAL
Body: Ø up to 2"	Brass CW 617 N-UNI-EN12165
Ø 2½" to 4"	Brass DELTA C EN1982 CB 7545
Bonnet	Brass CW 617 N-UNI-EN12165
Stem & Gland	Brass CW 614 N-UNI-EN12164
Packing	EPDM90 DUTRAL
Wedge	Brass DELTA C EN1982 CB 7545
Handwheel	Steel with blue plastic coating
Handwheel Nut	Steel Zinc plated



All data, descriptions and pictures contained in this leaflet may be subject to change without prior notice.

European Casting Industry Srl | Via Lazzaretto, 11 | 20124 Milan MI, Italia | P.Iva: 03228761205 | www.ecivalve.it | info@ecivalve.it

BS 910

BRASS AUTOMATIC AIR VENT

www.ecivalve.it

ECI EUROPEAN
CASTING
INDUSTRY

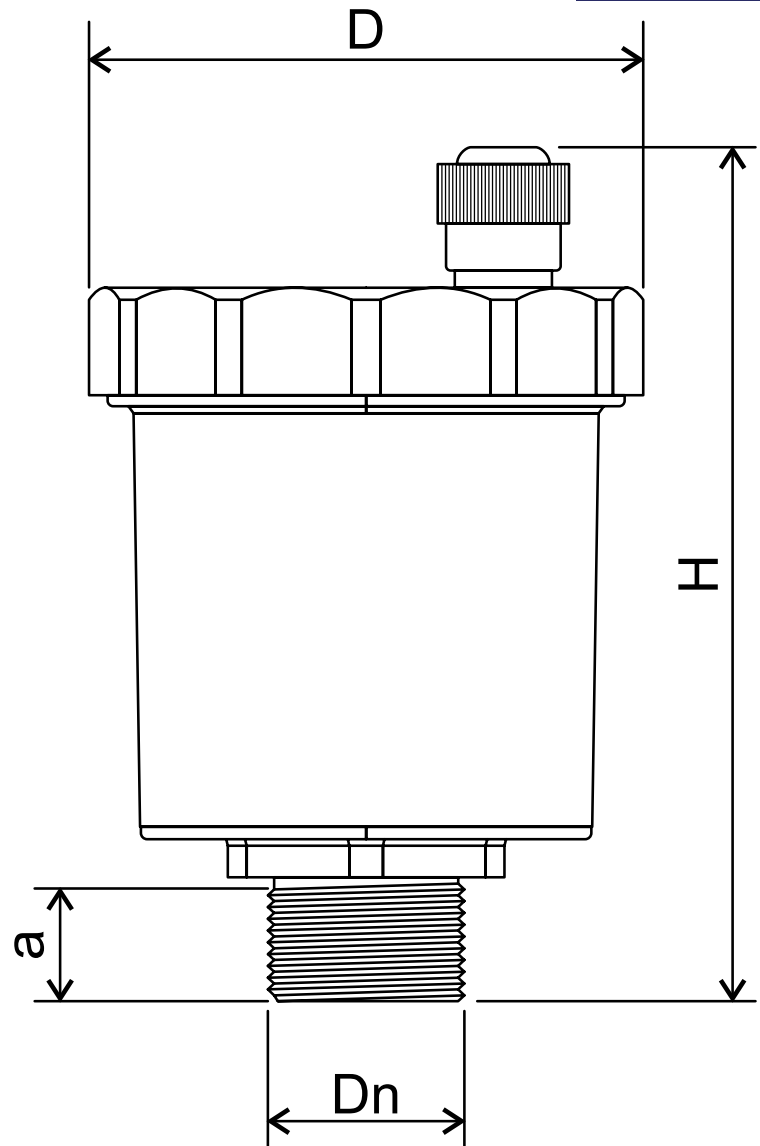

Specifications:

- WORKING PRESSURE: PN 10
- WORKING TEMPERATURE: $T \leq 110^{\circ}\text{C}$
- SINGLE AUTOMATIC FLOAT
- THREADING ACCORDING TO ISO 228/1
- SUITABLE FOR FLUID ACCORDING TO UNI 8065

Dimensions (mm)

DN	SIZE INCH	a	D	H	Weight(KGS)
10	3/8"	9	46	70	0.146
15	1/2"	9	46	70	0.157
20	3/4"	9	46	70	0.160
25	1"	13	46	70	0.190

Materials

DESCRIPTION	MATERIAL
Body	Brass EN 1982-CB754S
Seat	Brass EN 12164-CW617N
Seat Gasket	NBR
Float	Polypropilene PP
Spring	Stainless Steel AISI 302

ECI EUROPEAN
CASTING
INDUSTRY

All data, descriptions and pictures contained in this leaflet may be subject to change without prior notice.

European Casting Industry Srl | Via Lazzaretto, 11 | 20124 Milan MI, Italia | P.Iva: 03228761205 | www.ecivalve.it | info@ecivalve.it



Cast-Iron Valves

G 101	28
G 103	29
G 201	30
G 203	31
G 301	32
G 303	33
G 311	34
G 401	35
G 403	36
G 501	37
G 503	38
G 505	39
G 507	40
G 801	41

G 101

DUCTILE IRON BUTTERFLY VALVE WAFER SEMI-LUGGED TYPE WITH LEVER

Conforms to MSS SP-67 per art. 3 par. 3

www.ecivalve.it

ECI EUROPEAN
CASTING
INDUSTRY

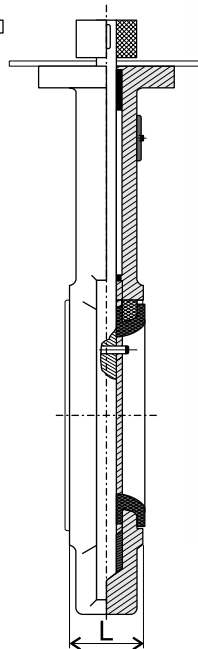
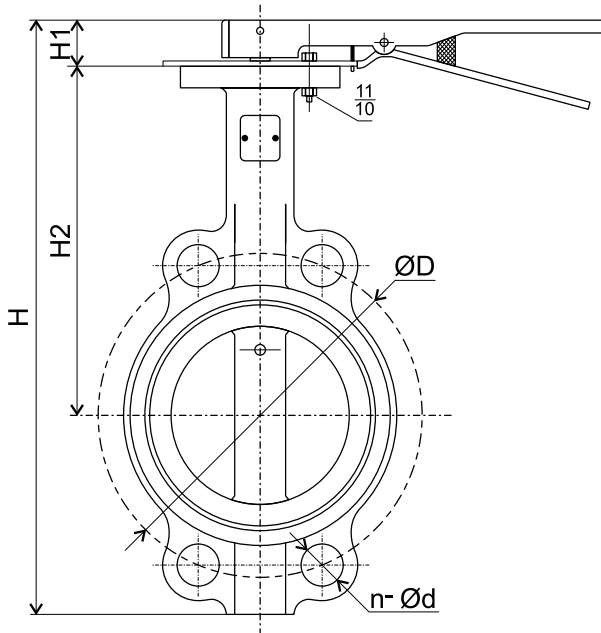

Specifications:

- WAFER SEMI-LUGGED TYPE BUTTERFLY VALVE WITH LEVER
- END CONNECTION SUITABLE FOR FLANGE CONNECTION ANSI B16.5 CLASS 150 OR PN16
- PRESSURE RATING 150 PSI
- DESIGNED & MANUFACTURED TO MEET MSS SP-67 STANDARD
- NOT SUITABLE FOR STEAM
- SUITABLE MEDIA: FRESH WATER, SEWAGE, SEA WATER, AIR, OIL, ACID & CORROSIVE MEDIA
- WORKING TEMPERATURE FROM -15 TO +120°C / -5°F TO +249°F

Materials

No.	DESCRIPTION	MATERIAL	AMERICAN STANDARD
1	Body	Ductile Iron	ASTM A 536 65-45-12
2	Seat	EPDM	-
3	Disc	Stainless Steel	SS304/316
4	Shaft	Stainless Steel	SS410

Dimensions (mm)

DN	H	H1	H2	Ød	n-Ød	BOLTS	L	WEIGHT KGS
50	273	32	161	121	4-Ø19	4 - 5/8" - 11UNC	42.0	2.50
65	296	32	175	140	4-Ø19	4 - 5/8" - 11UNC	45.0	3.10
80	308	32	181	153	4-Ø19	4 - 5/8" - 11UNC	44.5	3.70
100	346	32	200	191	4-Ø19	8 - 5/8" - 11UNC	51.0	5.20
125	372	32	213	216	4-Ø22	8 - 3/4" - 10UNC	54.5	6.50
150	397	32	226	242	4-Ø22	8 - 3/4" - 10UNC	54.8	8.50
200	480	40	260	299	4-Ø22	8 - 3/4" - 10UNC	59.6	14.00
250	545	50	295	362	4-Ø25	12 - 7/8" - 9UNC	67.0	21.00
300	634	55	310	432	4-Ø25	12 - 7/8" - 9UNC	75.9	32.00

ECI EUROPEAN
CASTING
INDUSTRY

All data, descriptions and pictures contained in this leaflet may be subject to change without prior notice.

European Casting Industry Srl | Via Lazzaretto, 11 | 20124 Milan MI, Italia | P.Iva: 03228761205 | www.ecivalve.it | info@ecivalve.it

G 103

DUCTILE IRON BUTTERFLY VALVE
 WAFER SEMI-LUGGED GEAR OPERATED
 Conforms to MSS SP-67

www.ecivalve.it

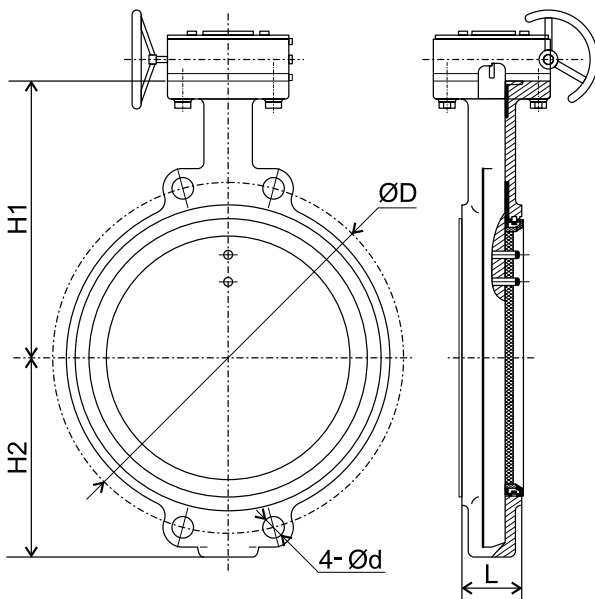

Specifications:

- WAFER SEMI-LUGGED TYPE BUTTERFLY VALVE WITH GEAR OPERATION
- END CONNECTION SUITABLE FOR FLANGE CONNECTION ANSI B16.5 CLASS 150 OR PN16
- PRESSURE RATING 150 PSI
- DESIGNED & MANUFACTURED TO MEET MSS-SP 67 STANDARD
- NOT SUITABLE FOR STEAM
- SUITABLE MEDIA: FRESH WATER, SEWAGE, SEA WATER, AIR, OIL, ACID & CORROSIVE MEDIA
- WORKING TEMPERATURE FROM -15 TO +120°C / -5°F TO +249°F

Materials

No.	DESCRIPTION	MATERIAL	AMERICAN STANDARD
1	Body	Ductile Iron	ASTM A 395
2	Seat	EPDM	-
3	Disc	Stainless Steel	SS304/316
4	Shaft	Stainless Steel	SS410

Dimensions (mm)

DN	H1	H2	Ød	4-Ød	BOLTS	L	WEIGHT KGS
150	226	139	242	4-Ø22	8 - 3/4" - 10UNC	54.8	11.50
200	260	175	299	4-Ø22	8 - 3/4" - 10UNC	59.6	19.50
250	292	203	362	4-Ø25	12 - 7/8" - 9UNC	67.0	25.00
300	337	242	432	4-Ø25	12 - 7/8" - 9UNC	75.9	38.00
350	368	267	476	4-Ø29	12 - 1" - 8UNC	75.5	44.00
400	400	309	540	4-Ø29	16 - 1" - 8UNC	90.0	72.00
450	422	327	578	4-Ø32	12 - 1 1/2" - 7UNC	104	85.00



All data, descriptions and pictures contained in this leaflet may be subject to change without prior notice.

European Casting Industry Srl | Via Lazzaretto, 11 | 20124 Milan MI, Italia | P.Iva: 03228761205 | www.ecivalve.it | info@ecivalve.it

G 201

CAST IRON STRAINER, Y TYPE

CL-125 FLANGED

www.ecivalve.it

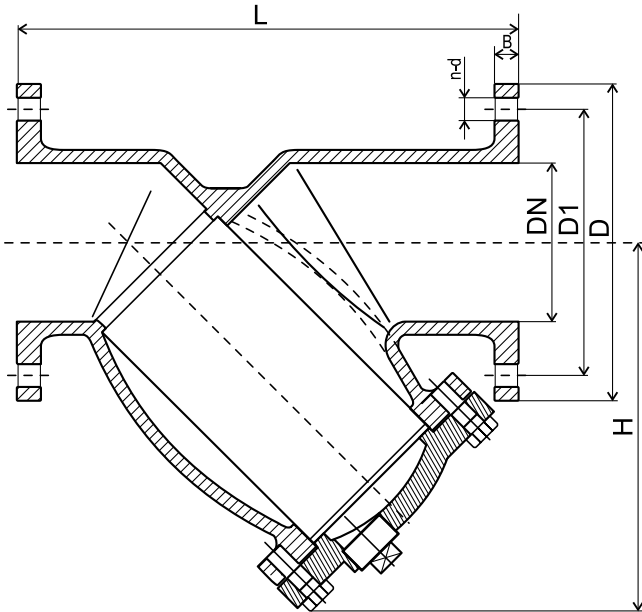

Specifications:

- 125 PSI/8.6 BAR SATURATED STEAM TO 353°F/178°C
- 200 PSI/13.8 BAR WOG FROM -10 TO 65 °C
- FLANGE DRILLED CONFORM TO ANSI B16.1 CL 125
- FACE TO FACE DIMENSION CONFORMS TO SERIES 1 OF BS EN 558-1
- SUITABLE MEDIA: WATERS, OIL, AIR & STEAM

Materials

No.	DESCRIPTION	MATERIAL	AMERICAN STANDARD
1	Body	Cast Iron	ASTM A 126 B
2	Screen	Stainless Steel	ANSI 304
3	Bonnet	Cast Iron	ASTM A 126 B
4	Gasket	Graphite	Non Asbestos
5	Screw Plug	Brass	ASTM B584 C84400
6	Bolt	Steel	ASTM A 307

Dimensions (mm)

DN	SIZE INCH	L	D	D1	B	f	n-d	H	WEIGHT KGS
50	2	230	152	121	20	3	4-19	156	10.1
65	2½	290	178	140	20	3	4-19	176	14.0
80	3	310	190	153	22	3	4-19	199	20.3
100	4	350	229	191	24	3	8-19	240	26.6
125	5	400	254	216	26	3	8-22	292	39.8
150	6	480	279	241	26	3	8-22	320	57.0
200	8	600	343	299	30	3	8-22	399	97.0
250	10	730	406	362	32	3	12-25	516	163.5
300	12	850	483	432	32	4	12-25	568	233.5
350	14	980	533	477	36	4	12-29	648	312.0
400	16	1100	597	540	38	4	16-29	759	422.0



All data, descriptions and pictures contained in this leaflet may be subject to change without prior notice.

European Casting Industry Srl | Via Lazzaretto, 11 | 20124 Milan MI, Italia | P.Iva: 03228761205 | www.ecivalve.it | info@ecivalve.it

G 203

CAST IRON STRAINER, Y TYPE

PN16 Flanged

www.ecivalve.it

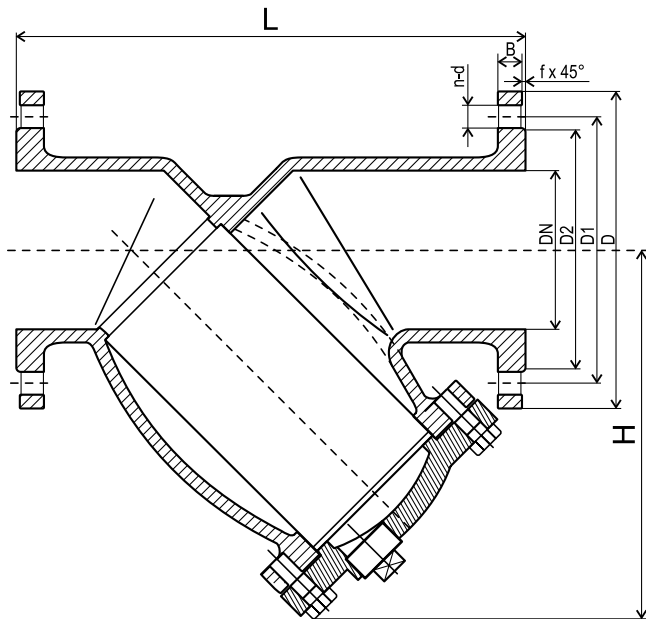

Specifications:

- 16 BAR FROM -10 TO 120 °C, 13 BAR AT 220 °C
- FLANGE DRILLED CONFORM TO BS-EN 1092-2 PN16
- FACE TO FACE DIMENSION CONFORMS TO SERIES 1 OF BS EN 558-1
- SUITABLE MEDIA: WATERS, OIL, AIR & STEAM

Materials

No.	DESCRIPTION	MATERIAL	BRITISH STANDARD
1	Body	Cast iron	1561EN JL 1030
2	Screen	Stainless	1449304S315
3	Bonnet	Cast Iron	1561EN JL 1030
4	Gasket	Graphite	Non Asbestos
5	Screw Plug	Brass	Mn Brass
6	Bolt	Steel	BS979 43A

Dimensions (mm)

DN	L	D	D1	D2	B	f	n-d	H	WEIGHT KGS
50	230	165	125	102	20	3	4-19	156	10.9
65	290	185	145	122	20	3	4-19	176	14.5
80	310	200	160	138	22	3	8-19	199	20.9
100	350	220	180	158	24	3	8-19	240	26.8
125	400	250	210	188	26	3	8-19	292	40.2
150	480	285	240	212	26	3	8-23	320	57.1
200	600	340	295	288	30	3	12-23	399	97.1
250	730	405	355	320	32	3	12-28	516	163.0
300	850	460	410	378	32	4	12-28	568	228.4
350	980	520	470	438	36	4	16-28	648	312.0
400	1100	580	525	490	38	4	16-31	759	422.0



All data, descriptions and pictures contained in this leaflet may be subject to change without prior notice.

European Casting Industry Srl | Via Lazzaretto, 11 | 20124 Milan MI, Italia | P.Iva: 03228761205 | www.ecivalve.it | info@ecivalve.it

G 301

CAST IRON SWING CHECK VALVE

CLASS 125

Conforms to MSS SP-71

www.ecivalve.it

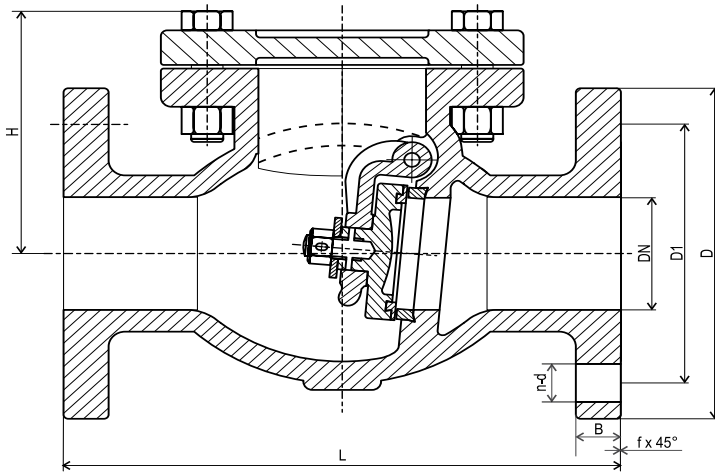

Specifications:

- 125 PSI/8.6 BAR SATURATED STEAM TO 449°F/232°C 200 PSI/13.8 BAR COLD WORKING PRESSURE FROM -20°F TO 150°F/-29°C TO 66°C
- TEST PRESSURES HYDRAULIC: BODY: 24 BAR, SEAT: 17.6 BAR
- DESIGN AND MANUFACTURE CONFORM TO MSS SP-71
- FACE TO FACE DIMENSIONS CONFORM TO ANSI B16.10
- FLANGE DRILLED CONFORMS TO ANSI B16.1 CLASS 125
- SUITABLE MEDIA: WATER & OIL
- BOLTED COVER
- SUITABLE FOR MOUNTING IN HORIZONTAL AND VERTICAL PIPELINES (WITH THE FLOW UPWARDS OR IN ANY INTERMEDIATE POSITION)

Dimensions (mm)

DN	SIZE INCH	L	D	D1	B	n-d	H	WEIGHT KGS
50	2	203	152	121	15.9	4-19	112	10.4
65	2.1/2	216	178	140	17.5	4-19	132	14.2
80	3	241	190	153	19.0	4-19	141	19.0
100	4	292	229	191	23.8	8-19	162	33.3
125	5	330	254	216	23.8	8-22	192	49.0
150	6	356	279	241	25.4	8-22	211	63.6
200	8	495	343	299	28.6	8-22	270	112.0
250	10	622	406	362	30.2	12-25	316	189.5
300	12	698	483	432	31.8	12-25	357	247.0
350	14	787	533	477	34.9	12-29	560	419
400	16	914	597	540	36.5	16-29	589	542
450	18	914	635	578	39.7	16-32	645	656
500	20	1016	699	635	42.9	20-32	702	832
600	24	1219	813	750	47.6	20-35	812	1260

Materials

No.	DESCRIPTION	MATERIAL	AMERICAN STANDARD
1	Body	Cast Iron	ASTM A 126 B
2	Seat Ring	Bronze	ASTM B 62
3	Disc Ring	Bronze	ASTM B 62
4	Disc	Cast Iron	ASTM A 126 B
5	Hanger	Ductile Iron	ASTM A536 60-40-18
6	Washer	Steel	ASTM A 307
7	Nut	Steel	ASTM A 307
8	Split Pin	Stainless Steel	ANSI 304
9	Disc Screw	Steel	ASTM A 307
10	Side Pin	Brass	ASTM B584 C84400
11	Gasket	Steel Cardboard	-
12	Hanger Pin	Stainless Steel	ANSI 304
13	Bonnet	Cast Iron	ASTM A 126 B
14	Gasket	Graphite	Non Asbestos
15	Bolt	Steel	ASTM A 307
16	Nut	Steel	ASTM A 307
17	Identification Plate	Aluminum	-
18	Pin	Stainless Steel	ANSI 304



All data, descriptions and pictures contained in this leaflet may be subject to change without prior notice.

European Casting Industry Srl | Via Lazzaretto, 11 | 20124 Milan MI, Italia | P.Iva: 03228761205 | www.ecivalve.it | info@ecivalve.it

G 303

CAST IRON SWING CHECK VALVE

BS PN16

Conforms to BS EN 12334:2001

www.ecivalve.it

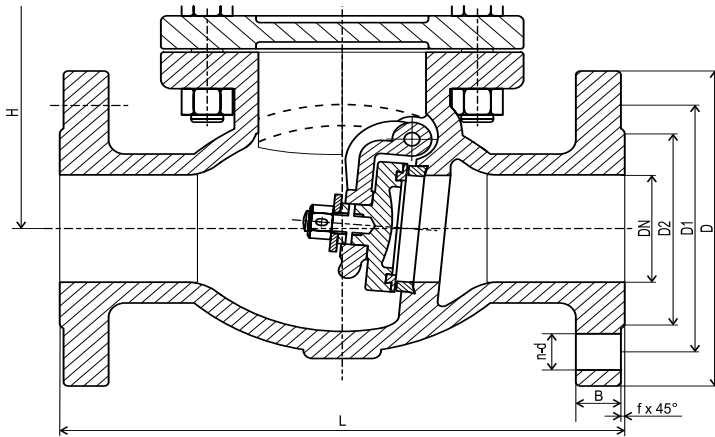

Specifications:

- PRESSURE-TEMPERATURE RATING: BS EN 1092-2 PN16 16 BAR FROM-10 TO 120°C 13 BAR AT 220°C
- TEST PRESSURES HYDRAULIC: BODY: 24 BAR, SEAT: 17.6 BAR
- DESIGN AND MANUFACTURE CONFORM TO BS5153 & BS EN 12334:2001
- FACE TO FACE DIMENSIONS CONFORM TO SERIES 10 OF BS EN 558 - 1
- FLANGE DRILLED CONFORMS TO BS EN 1092-2 PN16
- SUITABLE MEDIA: WATER & OIL
- BOLTED COVER
- SUITABLE FOR MOUNTING IN HORIZONTAL AND VERTICAL PIPELINES (WITH THE FLOW UPWARDS OR IN ANY INTERMEDIATE POSITION)

Dimensions (mm)

DN	L	D	D1	D2	B	n-d	F	H	WEIGHT KGS
50	203	165	125	102	20	4-19	3	112	11.2
65	216	185	145	122	20	4-19	3	132	14.4
80	241	200	160	138	22	8-19	3	141	20.0
100	292	220	180	158	24	8-19	3	162	31.5
125	330	250	210	188	26	8-19	3	192	47.0
150	356	285	240	212	26	8-23	3	211	63.5
200	495	340	295	288	30	12-23	3	270	106.4
250	622	405	355	320	32	12-28	3	316	184.5
300	698	460	410	378	32	12-28	4	357	238.5
350	787	520	470	438	36	16-28	4	560	419
400	914	580	525	490	38	16-31	4	589	542
450	914	640	585	550	40	20-31	4	645	656
500	1016	715	650	610	42	20-34	4	702	832
600	1219	840	770	725	48	20-37	5	812	1260

Materials

No.	DESCRIPTION	MATERIAL	BRITISH STANDARD
1	Body	Cast Iron	1561 EN JL 1030
2	Seat Ring	Bronze	1982 CC491K
3	Disc Ring	Bronze	1982 CC491K
4	Disc	Cast Iron	1561 EN JL 1030
5	Hanger	Ductile Iron	BS2789 Gr420-12
6	Washer	Steel	BS970 43A
7	Nut	Steel	BS970 43A
8	Split Pin	Stainless Steel	1449 304S315
9	Disc Screw	Steel	BS970 43A
10	Side Pin	Brass	Mn Brass
11	Gasket	Cardboard	-
12	Hanger Pin	Stainless Steel	1449 304S315
13	Bonnet	Cast Iron	1561 EN JL 1030
14	Gasket	Graphite	Non Asbestos
15	Bolt	Steel	BS970 43A
16	Nut	Steel	BS970 43A
17	Identification	Aluminum	-
18	Pin	Stainless Steel	1449 304S315



All data, descriptions and pictures contained in this leaflet may be subject to change without prior notice.

European Casting Industry Srl | Via Lazzaretto, 11 | 20124 Milan MI, Italia | P.Iva: 03228761205 | www.ecivalve.it | info@ecivalve.it

G 311

CAST IRON CHECK VALVE WAFER TYPE

ANSI 125 WP & PN 16

Conforms to MSS SP-125

www.ecivalve.it

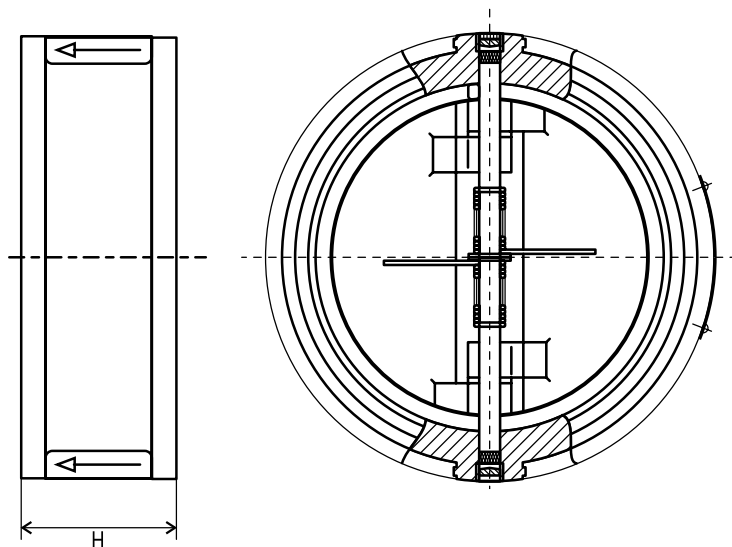
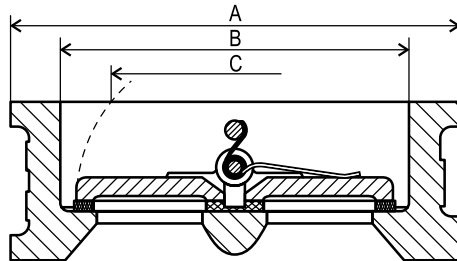

Specifications:

- PRESSURE RATING ANSI 125
- END CONNECTION SUITABLE FOR FLANGE CONNECTION ANSI B16.1 125 OR EN 1092-2 PN16
- USE ONLY FLAT FLANGES AND RING GASKETS
- FACE TO FACE DIMENSIONS CONFORM TO BS EN 558 SERIES 16
- TEMPERATURE OPERATING RANGE -20 TO 120°C
- SUITABLE FOR INSTALLATION IN VERTICAL AND HORIZONTAL PIPELINES
- IN VERTICAL PIPELINES, THE FLOW MUST BE IN AN UPWARD DIRECTION
- NOT SUITABLE FOR STEAM
- SUITABLE MEDIA: WATER, AIR, OIL, ACID AND CORROSIVE MEDIA

Materials

DN	SIZE INCH	A	B	C	H	WEIGHT KGS
50	2	105	65	42.5	54	1.5
65	2½	124	80	59.9	54	2.0
80	3	137	94	62.6	57	2.8
100	4	175	117	84.2	64	4.1
125	5	197	145	113	70	6.4
150	6	222	170	141	76	8.5
200	8	279	224	194	95	13.5
250	10	340	265	229	108	22.0
300	12	410	310	279	143	30.0
350	14	451	360	312	184	61.0
400	16	514	410	370	191	78.0
450	18	546	450	414	203	100.0

Dimensions (mm)

No.	DESCRIPTION	MATERIAL	AMERICAN STANDARD
1	Body: Up to 12" 14" to 18"	Cast Iron Ductile Iron	ASTM A 126 B ASTM A536 65-45-12
2	Disc	Stainless Steel	SS304/SS316
3	Liner	EPDM	-
4	Shaft	Stainless Steel	SS410
5	Spring	Stainless Steel	SS316



All data, descriptions and pictures contained in this leaflet may be subject to change without prior notice.

European Casting Industry Srl | Via Lazzaretto, 11 | 20124 Milan MI, Italia | P.Iva: 03228761205 | www.ecivalve.it | info@ecivalve.it

G 401

CAST IRON GLOBE VALVE
ANSI CL 125 FLANGED
OUTSIDE SCREW & YOKE
CONFORMS TO MSS SP-85

www.ecivalve.it

ECI EUROPEAN
CASTING
INDUSTRY

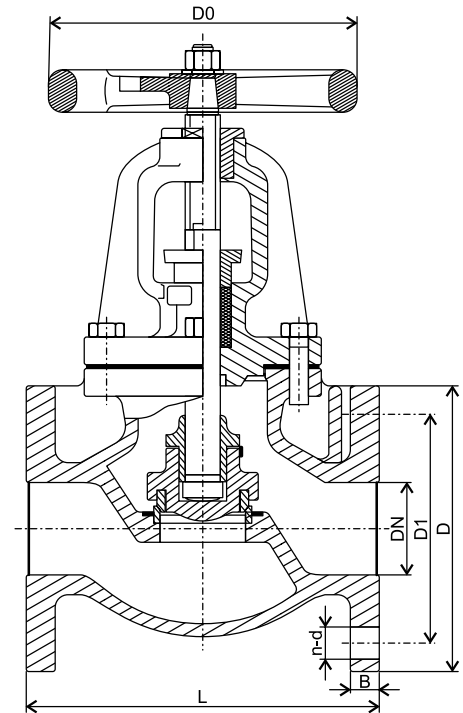

Specifications:

- OUTSIDE SCREW & YOKE
- 125 PSI/8.6 BAR FLUID PRESSURE TO 384°F/230°C
- 200 PSI/13.8 BAR NON-SHOCK COLD WORKING PRESSURE FROM -20°F TO 150°F/ -29°C TO 66°C
- SUITABLE MEDIA: WATER, OIL, AIR & STEAM
- DESIGN AND MANUFACTURE CONFORM TO MSS SP-85
- FACE TO FACE DIMENSIONS CONFORM TO ANSI B16.10
- FLANGE DRILLED CONFORM TO ANSI B16.1 CLASS 125

Dimensions (mm)

DN	NCH	L	D	D1	n-d	B	Do	WEIGHT KGS
50	2	203	152	121	4-19	15.9	180	15.6
65	2½	216	178	140	4-19	17.5	180	21.5
80	3	241	190	153	4-19	19.1	200	30.9
100	4	292	229	191	8-19	23.9	254	46.8
125	5	330	254	216	8-22	23.9	254	68.4
150	6	356	279	241	8-22	25.4	300	92.6
200	8	495	343	299	8-22	28.6	300	157
250	10	622	406	362	12-25	30.2	350	229
300	12	698	483	432	12-25	31.8	400	318

Materials

No.	DESCRIPTION	MATERIAL	AMERICAN STANDARD
1	Body	Cast Iron	ASTM A 126 B
2	Body Seat Ring	Bronze	ASTM B 62
3	Disc Seat Ring	Bronze	ASTM B 62
4	Disc	Cast Iron	ASTM A 126 B
5	Disc Washer	Stainless Steel	ANSI 304
6	Disc Nut	Stainless Steel	ANSI 304
7	Stem	Stainless Steel	ANSI 304
8	Gasket	Graphite	Non Asbestos
9	Bolt	Steel	ASTM A 307
10	Packing	Graphite	Non Asbestos
11	Bonnet	Cast Iron	ASTM A 126 B
12	Gland Flange	Ductile Iron	ASTM A536 60-40-18
13	Nut	Steel	ASTM A 307
14	Bolt	Steel	ASTM A 307
15	Stem Nut	Brass	ASTM B584 C84400
16	Handwheel	Cast Iron	ASTM A 126 B
17	Handwheel Washer	Steel	ASTM A 307
18	Handwheel Nut	Steel	ASTM A 307

ECI EUROPEAN
CASTING
INDUSTRY

All data, descriptions and pictures contained in this leaflet may be subject to change without prior notice.

European Casting Industry Srl | Via Lazzaretto, 11 | 20124 Milan MI, Italia | P.Iva: 03228761205 | www.ecivalve.it | info@ecivalve.it

G 403

CAST IRON GLOBE VALVE

BS PN16 FLANGED

Rising stem

Conforms to BS EN 13789:2010

www.ecivalve.it

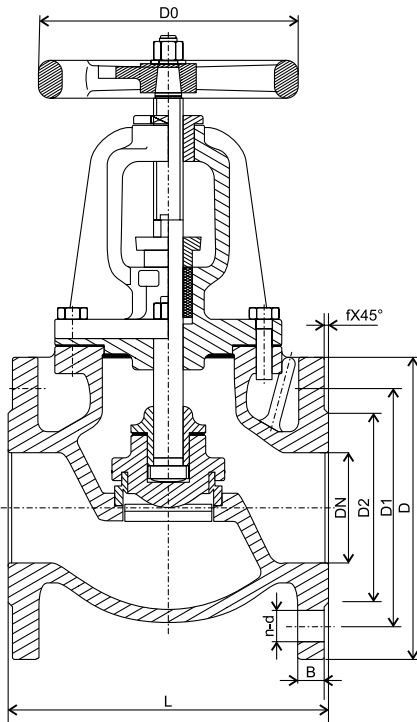

Specifications:

- OUTSIDE SCREW & YOKE
- PRESSURE-TEMPERATURE RATING: 16 BAR AT -10 TO 120°C 12.1 BAR AT 230°C
- TEST PRESSURES HYDRAULIC: SHELL: 24 BAR, SEAT: 17.6 BAR
- DESIGN AND MANUFACTURE CONFORM TO BS5152 (BS EN 13789:2010 PN16)
- FACE TO FACE DIMENSIONS CONFORM TO SERIES 10 OF BS EN 558-1
- FLANGE DRILLED CONFORM TO BS EN 1092-2 PN16
- GATE VALVES ARE DESIGNED TO BE IN AN OPEN OR CLOSED POSITION
- SUITABLE MEDIA: WATER, OIL, AIR & STEAM

Dimensions (mm)

DN	L	D	D1	D2	n-d	B	f	Do	WEIGHT KGS
50	203	165	125	102	4-19	20	3	180	16.4
65	216	185	145	122	4-19	20	3	180	22.0
80	241	200	160	138	8-19	22	3	200	31.5
100	292	220	180	158	8-19	24	3	254	46.0
125	330	250	210	188	8-19	26	3	254	68.7
150	356	285	240	212	8-23	26	3	300	92.8
200	495	340	295	288	12-23	30	3	300	157
250	622	405	355	320	12-28	32	3	350	228
300	698	460	410	378	12-28	32	4	400	313

Materials

No.	DESCRIPTION	MATERIAL	BRITISH STANDARD
1	Body	Cast Iron	1561 EN JL 1030
2	Body Seat Ring	Bronze	1982 CC 491K
3	Disc Seat Ring	Bronze	1982 CC 491K
4	Disc	Cast Iron	1561 EN JL 1030
5	Disc Washer	Stainless Steel	1449 304S315
6	Nut	Brass	12164 CW603R
7	Stem	Stainless Steel	1449 304S315
8	Flange Gasket	Graphite	Non Asbestos
9	Bolt	Steel	BS970 43A
10	Packing	Graphite	Non Asbestos
11	Bonnet	Cast Iron	1561 EN JL 1030
12	Gland	Ductile Iron	BS2789 Gr.420-12
13	Nut	Steel	BS970 43A
14	Bolt	Steel	BS970 43A
15	Stem	Brass	12164 CW603R
16	Handwheel	Cast Iron	1561 EN JL 1030
17	Handwheel Washer	Steel	BS970 43A
18	Handwheel Nut	Steel	BS970 43A



All data, descriptions and pictures contained in this leaflet may be subject to change without prior notice.

European Casting Industry Srl | Via Lazzaretto, 11 | 20124 Milan MI, Italia | P.Iva: 03228761205 | www.ecivalve.it | info@ecivalve.it

G 501

CAST IRON GATE VALVE

ANSI CL 125 FLANGED

Non-Rising stem

Conforms to MSS SP-70

www.ecivalve.it

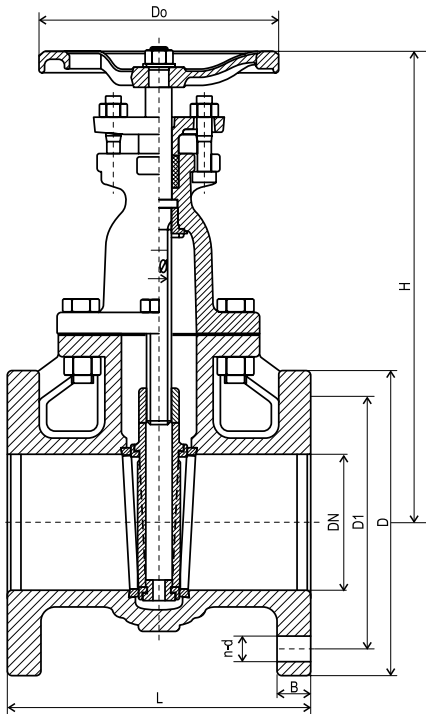

Specifications:

- INSIDE SCREW NON-RISING STEM
- 125 PSI/8.6 BAR FLUID PRESSURE TO 353°F/178°C
- 200 PSI/13.8 BAR NON-SHOCK COLD WORKING PRESSURE FROM -20°F TO 150°F/-29°C TO 66°C
- SUITABLE MEDIA: WATER & OIL
- DESIGN AND MANUFACTURE CONFORM TO MSS SP-70
- FACE TO FACE DIMENSIONS CONFORM TO ANSI B16.10
- FLANGE DRILLED CONFORM TO ANSI B16.1 CLASS 125
- GATE VALVES ARE DESIGNED TO BE IN AN OPEN OR CLOSED POSITION

Dimensions (mm)

DN	SIZE INCH	L	D	D1	n-d	B	Do	H	WEIGHT KG
50	2	178	152	121	4-19	15.9	180	240	12.0
65	2½	190	178	140	4-19	17.5	180	265	15.4
80	3	203	190	153	4-19	19.1	200	323	22.6
100	4	229	229	191	8-19	23.9	254	365	35.8
125	5	254	254	216	8-22	23.9	254	413	47.6
150	6	267	279	241	8-22	25.4	300	477	63.0
200	8	292	343	299	8-22	28.6	300	585	106
250	10	330	406	362	12-25	30.2	350	710	168
300	12	356	483	432	12-25	31.8	400	789	243
350	14"	381	533.4	476.3	12-28.6	34.9	560	987	391
400	16"	406.4	597	539.8	16-28.6	36.5	560	1044	520
450	18"	432	635	578	16-32	39.7	610	1148	684
500	20"	457	699	635	20-32	42.9	610	1257	800
600	24"	508	813	749.5	20-35	47.6	765	1418	1205

Materials

No.	DESCRIPTION	MATERIAL	AMERICAN STANDARD
1	Body	Cast Iron	ASTM A 126 B
2	Body Seat Ring	Bronze	ASTM B 62
3	Wedge Seat Ring	Bronze	ASTM B 62
4	Wedge	Cast Iron	ASTM A 126 B
5	Stem	Brass	ASTM B 16
6	Stem Nut	Brass	ASTM B584 C84400
7	Gasket	Graphite	Non Asbestos
8	Bolt	Steel	ASTM A 307
9	Nut	Steel	ASTM A 307
10	Bonnet	Cast Iron	ASTM A 126 B
11	Bonnet Bush	Brass	ASTM B584 C84400
12	Packing	Graphite	Non Asbestos
13	Gland Follower	Ductile Iron	ASTM A536 60-40-18
14	Bolt	Steel	ASTM A 307
15	Nut	Steel	ASTM A 307
16	Handwheel	Cast Iron	ASTM A 126
17	Washer	Steel	ASTM A 307
18	Handwheel Nut	Steel	ASTM A 307



All data, descriptions and pictures contained in this leaflet may be subject to change without prior notice.

European Casting Industry Srl | Via Lazzaretto, 11 | 20124 Milan MI, Italia | P.Iva: 03228761205 | www.ecivalve.it | info@ecivalve.it

G 503

CAST IRON GATE VALVE

BS PN16 FLANGED

Non-Rising stem

Conforms to BS EN 1171:2002 PN16

www.ecivalve.it

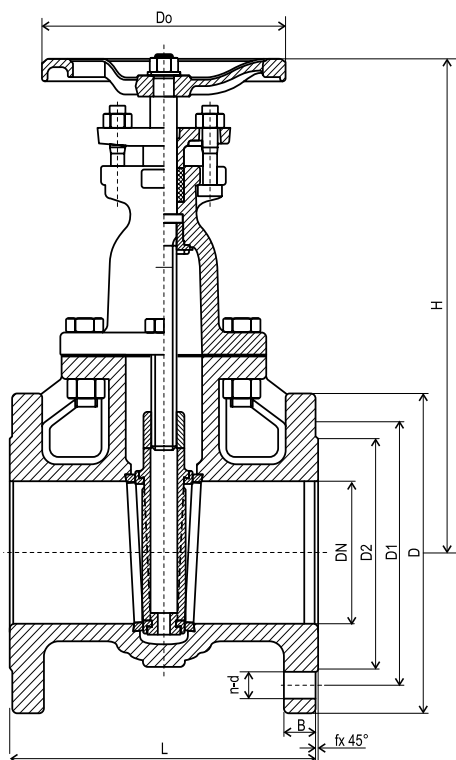

Specifications:

- PRESSURE-TEMPERATURE RATING: 16 BAR AT -10 TO 120°C 12.8 BAR AT 200°C
- TEST PRESSURES HYDRAULIC: SHELL: 24 BAR, SEAT: 17.6 BAR
- DESIGN AND MANUFACTURE CONFORM TO BS5150 (BS EN 1171:2002 PN 16)
- FACE TO FACE DIMENSIONS CONFORM TO SERIES 3 OF BS EN 558-1
- FLANGE DRILLED CONFORM TO BS EN 1092-2 PN 16
- GATE VALVES ARE DESIGNED TO BE IN AN OPEN OR CLOSED POSITION
- SUITABLE MEDIA: WATER & OIL

Dimensions (mm)

DN	L	D	D1	D2	n-d	B	f	Do	H	WEIGHT KGS
50	178	165	125	102	4-19	20	3	180	240	13.5
65	190	185	145	122	4-19	20	3	180	265	16.7
80	203	200	160	138	8-19	22	3	200	323	23.3
100	229	220	180	158	8-19	24	3	254	365	35.9
125	254	250	210	188	8-19	26	3	254	413	48.5
150	267	285	240	212	8-23	26	3	300	477	66.5
200	292	340	295	288	12-23	30	3	300	585	102
250	330	405	355	320	12-28	32	3	350	710	174
300	356	460	410	378	12-28	32	4	400	789	230
350	381	520	470	429	16-28	36	4	560	987	420
400	406.4	580	525	480	16-31	38	4	560	1044	598
450	432	640	585	548	20-31	40	4	610	1148	733
500	457	715	650	609	20-34	42	4	610	1257	937
600	508	840	770	720	20-37	48	5	765	1418	1211

Materials

No.	DESCRIPTION	MATERIAL	BRITISH STANDARD
1	Body	Cast iron	1561 EN JL 1030
2	Body Seat Ring	Bronze	1982 CC 491K
3	Wedge Seat Ring	Bronze	1982 CC 491K
4	Wedge	Cast Iron	1561 EN JL 1030
5	Stem	Brass	12164 CW603R
6	Stem Nut	Brass	Mn Brass
7	Gasket	Graphite	Non Asbestos
8	Bolt	Steel	BS970 43A
9	Nut	Steel	BS970 43A
10	Bonnet	Cast Iron	1561 EN JL 1030
11	Bonnet Bush	Brass	Mn Brass
12	Packing	Graphite	Non Asbestos
13	Gland Follower	Ductile Iron	BS2789 Gr.420-12
14	Bolt	Steel	BS970 43A
15	Nut	Steel	BS970 43A
16	Handwheel	Cast Iron	1561 EN JL 1030
17	Handwheel Washer	Steel	BS970 43A
18	Handwheel Nut	Steel	BS970 43A



All data, descriptions and pictures contained in this leaflet may be subject to change without prior notice.

European Casting Industry Srl | Via Lazzaretto, 11 | 20124 Milan MI, Italia | P.Iva: 03228761205 | www.ecivalve.it | info@ecivalve.it

G 505

CAST IRON GATE VALVE

ANSI CL 125 FLANGED

Rising stem

Conforms to MSS SP-70

www.ecivalve.it

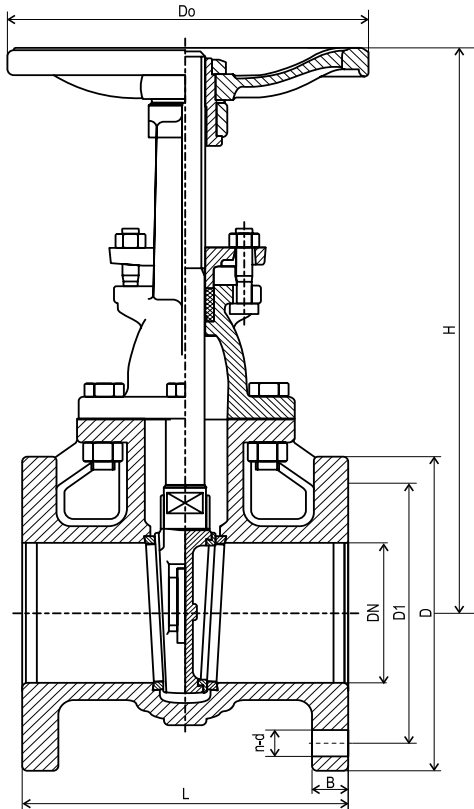

Specifications:

- OUTSIDE SCREW & YOKE
- 125 PSI/8.6 BAR FLUID PRESSURE TO 353°F/178°C
- 200 PSI/13.8 BAR NON-SHOCK COLD WORKING PRESSURE FROM -20°F TO 150°F/-29°C TO 66°C
- TEST PRESSURE SHELL 24.1 BAR & SEAT 13.8 BAR
- SUITABLE MEDIUM: WATER & OIL
- DESIGN AND MANUFACTURE CONFORM TO MSS SP-70
- FACE TO FACE DIMENSIONS CONFORM TO ANSI B16.10
- FLANGE DIMENSIONS CONFORM TO ANSI B16.1 CLASS 125
- GATE VALVES ARE DESIGNED TO BE IN AN OPEN OR CLOSED POSITION

Dimensions (mm)

DN	SIZE INCH	L	D	D1	n-d	B	Do	H CLOSED	WEIGHT KG
50	2	178	152	121	4-19	15.9	180	258	13.1
65	2½	190	178	140	4-19	17.5	180	302	17.4
80	3	203	190	153	4-19	19.1	200	341	22.8
100	4	229	229	191	8-19	23.9	254	415	37.5
125	5	254	254	216	8-22	23.9	254	484	48.0
150	6	267	279	241	8-22	25.4	300	560	64.7
200	8	292	343	299	8-22	28.6	300	703	106.0
250	10	330	406	362	12-25	30.2	350	865	178.2
300	12	356	483	432	12-25	31.8	400	1028	266.9

Materials

No.	DESCRIPTION	MATERIAL	AMERICAN STANDARD
1	Body	Cast iron	ASTM A 126 B
2	Body Seat Ring	Bronze	ASTM B 62
3	Wedge Seat Ring	Bronze	ASTM B 62
4	Wedge	Cast Iron	ASTM A 126 B
5	Stem	Brass	ASTM B 16
6	Gasket	Graphite	Non-Asbestos
7	Bolt	Steel	ASTM 307
8	Nut	Steel	ASTM 307
9	Bonnet	Cast Iron	ASTM A 126 B
10	Packing	Graphite	Non-Asbestos
11	Gland Follower	Ductile Iron	ASTM A536 60-40-18
12	Bolt	Steel	ASTM 307
13	Nut	Steel	ASTM 307
14	Stem Nut	Brass	ASTM B584 C884400
15	Handwheel Washer	Brass	ASTM B584 C884400
16	Handwheel	Cast Iron	ASTM A 126 B
17	Handwheel Nut	Steel	ASTM 307



All data, descriptions and pictures contained in this leaflet may be subject to change without prior notice.

European Casting Industry Srl | Via Lazzaretto, 11 | 20124 Milan MI, Italia | P.Iva: 03228761205 | www.ecivalve.it | info@ecivalve.it

G 507

CAST IRON GATE VALVE

PN 16 FLANGED

RISING STEM

Conforms to BS EN 1171:2002 PN16

www.ecivalve.it

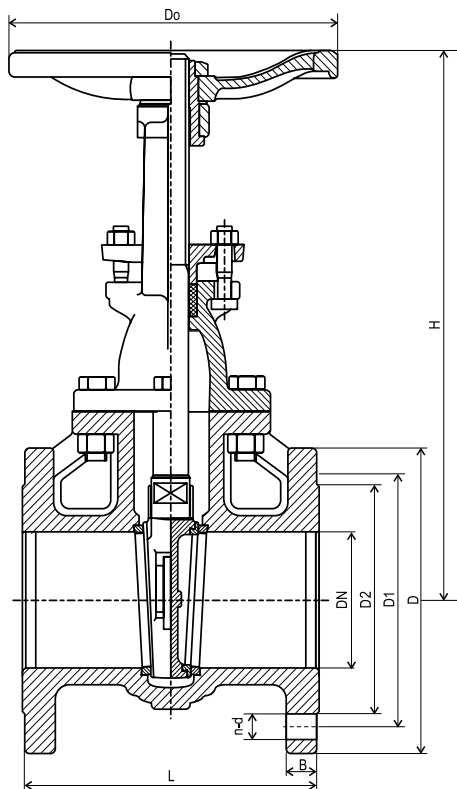

Specifications:

- OUTSIDE SCREW & YOKE
- PRESSURE-TEMPERATURE RATING: 16 BAR AT -10 TO 120°C 12.8 BAR AT 200°C
- TEST PRESSURES HYDRAULIC: SHELL: 24 BAR, SEAT: 17.6 BAR
- DESIGN AND MANUFACTURE CONFORM TO BS5150 (BS EN 1171:2002 PN 16)
- FACE TO FACE DIMENSIONS CONFORM TO SERIES 3 OF BS EN 558-1
- FLANGE DRILLED CONFORM TO BS EN 1092-2 PN 16
- GATE VALVES ARE DESIGNED TO BE IN AN OPEN OR CLOSED POSITION
- SUITABLE MEDIA: WATER & OIL

Dimensions (mm)

DN	L	D	D1	D2	n-d	B	f	Do	H CLOSED	WEIGHT KGS
50	178	165	125	102	4-19	20	3	180	240	14.1
65	190	185	145	122	4-19	20	3	180	265	18.2
80	203	200	160	138	8-19	22	3	200	323	23.8
100	229	220	180	158	8-19	24	3	254	365	36.1
125	254	250	210	188	8-19	26	3	254	413	48.9
150	267	285	240	212	8-23	26	3	300	477	66.3
200	292	340	295	288	12-23	30	3	300	585	102
250	330	405	355	320	12-28	32	3	350	710	184
300	356	460	410	378	12-28	32	4	400	789	254

Materials

No.	DESCRIPTION	MATERIAL	BRITISH STANDARD
1	Body	Cast Iron	1561 EN JL 1030
2	Seat Ring	Bronze	1982 CC 491K
3	Wedge Seat Ring	Bronze	1982 CC 491K
4	Wedge	Cast Iron	1561 EN JL 1030
5	Stem	Brass	12164 CW603R
6	Gasket	Graphite	Non Asbestos
7	Bolt	Steel	Steel
8	Nut	Steel	Steel
9	Bonnet	Cast Iron	1561 EN JL 1030
10	Packing	Graphite	Non Asbestos
11	Gland Follower	Ductile Iron	ASTM A536 60-40-18
12	Bolt	Steel	Steel
13	Nut	Steel	Steel
14	Stem Nut	Brass	Mn Brass
15	Handwheel Washer	Brass	Mn Brass
16	Handwheel	Cast Iron	EN JL 1030
17	Handwheel Nut	Steel	Steel



All data, descriptions and pictures contained in this leaflet may be subject to change without prior notice.

European Casting Industry Srl | Via Lazzaretto, 11 | 20124 Milan MI, Italia | P.Iva: 03228761205 | www.ecivalve.it | info@ecivalve.it

G 801

DUCTILE IRON BALANCING VALVE VARIABLE ORIFICE DOUBLE REGULATING VALVE (VODRV)

FLANGED TO CLASS 125 OR PN16
Conforms to BS 7350 PN16

www.ecivalve.it

ECI EUROPEAN
CASTING
INDUSTRY

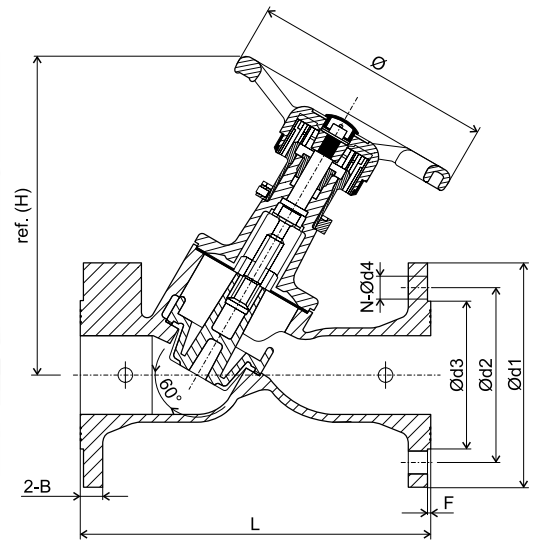

Pressure / Temperature Ratings

TEMPERATURE (°C)	PRESSURE (BAR)
-10 to 120	16.0

Ratings align with BS EN 1092-2 PN16
(formerly BS 4504) or CL 125

Materials

	PART NAME	MATERIAL	BRITISH STANDARD
1	Body	Ductile Iron	EN-JS 1040/65-45-12
2	Seal Gasket	EPDM	EPDM
3	Disc	Brass	EN12165 CW617N
4	Stem Nut	Brass	EN12165 CW617N
5	Stem	Stainless Steel	From DN65-DN300 BS970 410S21
			From DN350-DN500 BS970 431S29 DN600 SS630
6	Cover	Ductile Iron	EN-JS 1040
7	Stem Locking Bush	Brass	EN12165 CW617N
8	Limit Set of Indicator	Brass	From DN65-DN300 EN12165 CW617N+Galvanization
		Stainless Steel	From DN350-DN600 BS970 304S15
9	Oriented Set of Indicator	Brass	EN12165 CW617N
10	Directed Circle	ABS	ABS
11	Indicator	ABS	ABS
12	Packing	PTFE+EPDM	PTFE+EPDM
13	Hand wheel	Ductile Iron	EN-JS 1040/65-45-12
14	Plug	Steel	Steel
15	Bolt	Stainless Steel	BS970 304S15
16	Big Gasket	Stainless Steel	BS970 304S15
17	Hexagon Socket Screws	Stainless Steel	BS970 304S15
18	Bolt	Stainless Steel	BS970 304S15
19	Spring Gasket	Stainless Steel	BS970 304S15
20	Indicator Dust Cover	ABS	ABS
21	Packing Gland	Brass	From DN65-DN150 EN12165 CW617N
		Ductile Iron	From DN200-DN600 EN-JS 1040/65-45-12

Specifications:

- Y PATTERN GLOBE VALVE SUPPLIED WITH TWO TEST POINTS
- PROVIDE FLOW MEASUREMENT & REGULATION
- TO BE USED FOR ISOLATING & TO BE REOPENED TO IT'S PRESET POSITION
- ACCURACY ± 5% ON ALL SETTING
- DESIGN & MANUFACTURE CONFORM TO BS 7350 PN16
- SUITABLE MEDIUM: WATER
- WORKING TEMPERATURE: T ≤ 120° C

Coefficients

DN	FLOW (Kv)	HEADLOSS (K)
65	104	5.32
80	116	6.48
100	213	13.15
125	333	8.32
150	476	7.33
200	768	8.26
250	1153	7.27
300	1743	8.36

*Fully open position.

Dimensions (mm)

DN	H	L	B	Ø	Ød1	Ød2	Ød3	N-Ød4	F
65	263	290	19	200	185	145	118	4-Ø 19	3
80	268	310	19	200	200	160	132	8-Ø 19	3
100	300	350	19	240	220	180	156	8-Ø 19	3
125	328	400	19	290	250	210	184	8-Ø 19	3
150	340	480	19	290	285	240	211	8-Ø 23	3
200	525	600	20	350	340	295	266	12-Ø 23	3
250	572	730	22	420	405	355	319	12-Ø 28	3
300	686	850	24.5	420	460	410	370	12-Ø 28	4
350	681	980	26.5	420	520	470	429	16-Ø 28	4
400	965	1100	28	640	580	525	480	16-Ø 31	4
450	972	1200	30	640	640	585	548	20-Ø 31	4
500	1065	1250	31.5	640	715	650	609	20-Ø 34	4
600	1180	1450	36	640	840	770	720	20-Ø 37	5

ECI EUROPEAN
CASTING
INDUSTRY

All data, descriptions and pictures contained in this leaflet may be subject to change without prior notice.

European Casting Industry Srl | Via Lazzaretto, 11 | 20124 Milan MI, Italia | P.Iva: 03228761205 | www.ecivalve.it | info@ecivalve.it





Pressure Independent Control Valves (PICV)

BS 925 (PICV)

44

BS 925 (PICV)

PRESSURE INDEPENDENT CONTROL VALVE

PN 25

www.ecivalve.it

ECI EUROPEAN
CASTING
INDUSTRY



The pressure independent control valve, combines an automatic control of the flow rate with a control of the valve through an actuator. The valve is able to regulate the flow rate and keep it constant as the differential pressure conditions vary within the hydraulic circuit in which it is installed. The valve can be used with two operating modes:

- independent control of the pressure (with actuator installed) in accordance with the thermal load requirements of the circuit section to be controlled;
- limitation of the flow rate and/or shut-off of the fluid (without actuator or with thermo-electric actuator installed).

Versioni e codici

Code	DN Valve Body Size	Connections	Indicator Colour	Handwheel Colour	WORKING FLOW RATE RANGE [l/h]		WORKING DIFFERENTIAL PRESSURE RANGE [kPa]	
					L (LOW)	H (HIGH)	WITH V1100/ V1200 ACTUATORS	WITHOUT ACTUATOR
BS925 0015	15	G 1/2" M with tail pieces	BLUE	SKY-BLUE	150÷380 l/h	180÷630 l/h	25÷400 kPa	25÷800 kPa
BS9250020	20	G 3/4" M with tail pieces	BLACK	SKY-BLUE	320÷910 l/h	700÷1175 l/h	25÷400 kPa	25÷800 kPa
BS9250025	20	G 1" M with tail pieces	GREEN	SKY-BLUE	290÷1000 l/h	860÷1500 l/h	25÷400 kPa	25÷800 kPa
BS9250032	25	G 1-1/4" M with tail pieces	BLACK	SKY-BLUE	400÷4700 l/h		U/A	25÷400 kPa

Accessories:

- V1100 - Thermo-electric Actuator normally closed 230V
- V1200 - Thermo-electric Actuator normally closed 24V

ECI EUROPEAN
CASTING
INDUSTRY

All data, descriptions and pictures contained in this leaflet may be subject to change without prior notice.

European Casting Industry Srl | Via Lazzaretto, 11 | 20124 Milan MI, Italia | P.Iva: 03228761205 | www.ecivalve.it | info@ecivalve.it

BS 925 (PICV)

PRESSURE INDEPENDENT CONTROL VALVE

PN 25

www.ecivalve.it

ECI EUROPEAN
CASTING
INDUSTRY

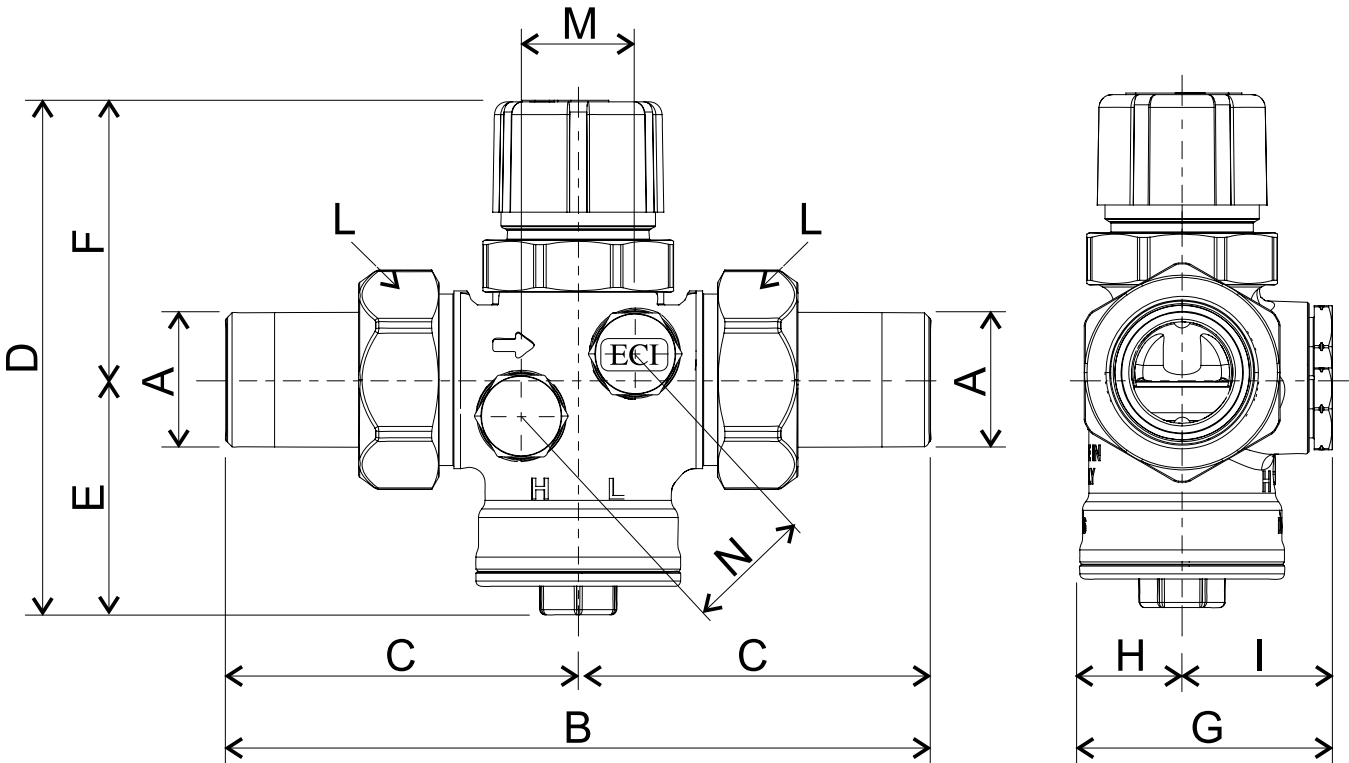

Dimensions (mm)

DN Valve Body Size	A Connections	B	C	D	E	F	G	H	I	L	M	Weight(KGS)
15	G 1/2" M	128	64	99	45	54	49	20	29	ch.30	22	0.625
20	G 3/4" M	136	68	99	45	54	49	20	29	ch.38	22	0.78
20	G 1" M	142	71	99	45	54	49	20	29	ch.38	22	0.825
25	G 1.1/4" M	165	83	111	52	59	65	30	35	ch.53	27	1.56

Technical data:

- Fluids: water, glycol solutions (max. 50 % glycol)
- Temperature range: 5÷120 °C
- Room temperature range: 1÷50 °C
- Max. working pressure: 25 bar (2,5 MPa)
- Working differential pressure range: see table at pag.1
- Working flow rate range: see table at pag.1
- Regulation precision: ± 10 % regulated value
- Leakage rate (according to ISO 5208): class A, no leakage
- Connections for pressure outlets: G 1/4" F
- Actuator connection: M30 x 1,5 mm

ECI EUROPEAN
CASTING
INDUSTRY

All data, descriptions and pictures contained in this leaflet may be subject to change without prior notice.

European Casting Industry Srl | Via Lazzaretto, 11 | 20124 Milan MI, Italia | P.Iva: 03228761205 | www.ecivalve.it | info@ecivalve.it

BS 925 (PICV)

PRESSURE INDEPENDENT CONTROL VALVE

PN 25

www.ecivalve.it

ECI EUROPEAN
CASTING
INDUSTRY

Materials:	
DESCRIPTION	MATERIAL
Body	Brass CW602n - UNI EN 12165
Bonnet	Brass CW602n - UNI EN 12165
Tail Pieces	Brass CW617N - UNI EN 12165
Regulator Stem & Piston	Stainless Steel AISI 302
Spring	Stainless Steel AISI 302
Membrane	EPDM
Stopper	EPDM
O-Ring	EPDM
Bonnet Seperator	PA66-GF30

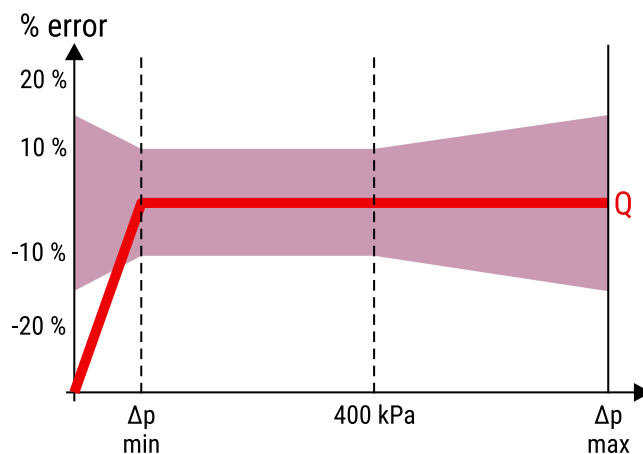

Operation

Through the manual handwheel it is possible to isolate the circuit section controlled by the valve. Turn the knob clockwise to close the handwheel;

counterclockwise to open it.

- with handwheel closed the complete flow shut-off is obtained;
- with handwheel open the flow rate limitation function is obtained at the preset value (see paragraph "Flow rate presetting").

The same function can also be obtained automatically by installing a thermoelectric actuator of the ON/OFF type, suitably electrically connected:

- with thermo-electric actuator closed the complete flow shut-off is obtained;
- with thermo-electric actuator open the flow rate stabilization function is obtained at the preset value (see paragraph "Flow rate presetting").

BS 925 (PICV)

PRESSURE INDEPENDENT CONTROL VALVE

PN 25

www.ecivalve.it

ECI EUROPEAN
CASTING
INDUSTRY

Flow-rate presetting

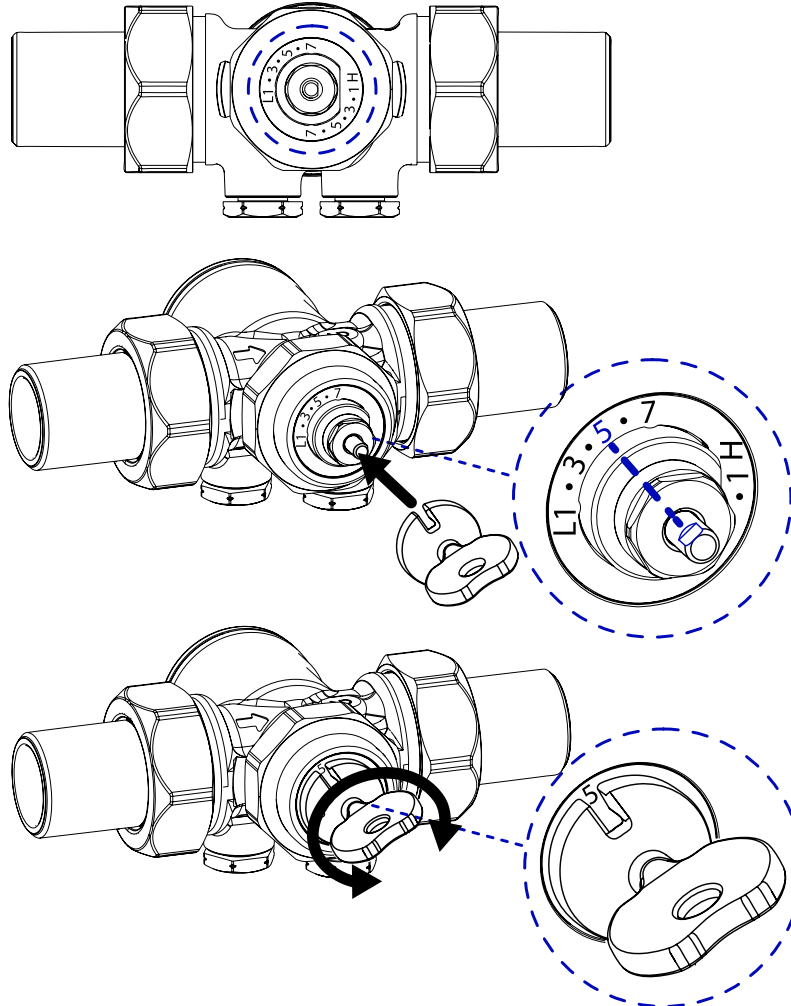

The BS9250015/20/25 valves are equipped with a double regulation scale of the flow rate:

- **L (LOW)**: for low flow rate
- **H (HIGH)**: for high flow rate

To set the valve adjustment based on the desired flow rate, use the **regulation key included in the package** and turn the valve stem clockwise or counterclockwise until reaching the desired value printed on the plastic disk of the valve and identifiable through the table below. The transition from one regulation scale to the other is possible at any time, even during the operation of the system; in this way it is possible to choose the desired flow rate value without having to replace the valve.

The BS9250032 valves, instead, are equipped with a single regulation scale of the flow rate.

Example:

Design flow rate: 300 l/h
Piping DN15



Valve required: BS9250015
Regulation scale: L (LOW)
Position: 5

ECI EUROPEAN
CASTING
INDUSTRY

All data, descriptions and pictures contained in this leaflet may be subject to change without prior notice.

European Casting Industry Srl | Via Lazzaretto, 11 | 20124 Milan MI, Italia | P.Iva: 03228761205 | www.ecivalve.it | info@ecivalve.it

BS 925 (PICV)

PRESSURE INDEPENDENT CONTROL VALVE

PN 25

www.ecivalve.it



Flow-rate presetting

Product Code	DN	Connections	WORKING DIFFERENTIAL PRESSURE RANGE [kPa]		WORKING FLOW RATE RANGE [l/h]										
			WITH V1100/V1200 Actuators	Without Actuator	Regulation	MIN	1	2	3	4	5	6	7	8	9
BS925 0015	15	G 1/2"M	25÷400 kPa	25÷800 kPa	L (LOW)	-	150	175	200	250	300	340	380	-	-
					H (HIGH)	-	180	250	350	440	500	570	630	-	-
BS9250020	20	G 3/4"M	25÷400 kPa	25÷800 kPa	L (LOW)	-	320	400	520	640	770	870	910	-	-
					H (HIGH)	-	700	820	910	970	1030	1100	1175	-	-
BS9250025	20	G 1"M	25÷400 kPa	25÷800 kPa	L (LOW)	-	290	400	500	640	730	900	1000	-	-
					H (HIGH)	-	860	900	940	1110	1270	1330	1500	-	-
BS9250032	25	G 1-1/4"M	U/	25÷400 kPa	A	-	400	670	1200	1800	2300	3000	3600	4300	4700

Installation

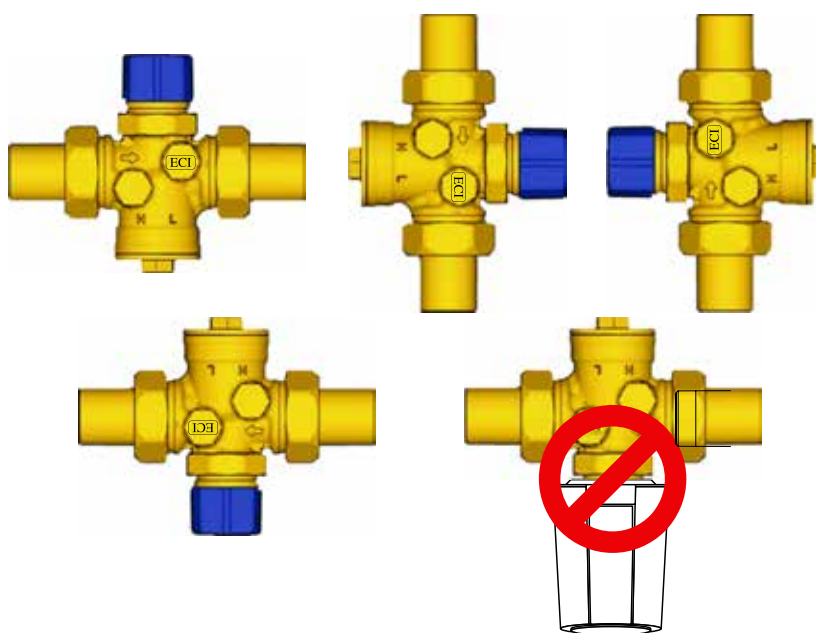
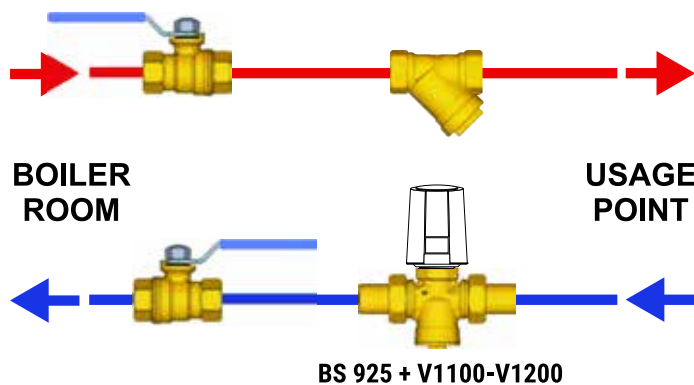

All data, descriptions and pictures contained in this leaflet may be subject to change without prior notice.

European Casting Industry Srl | Via Lazzaretto, 11 | 20124 Milan MI, Italia | P.Iva: 03228761205 | www.ecivalve.it | info@ecivalve.it

BS 925 (PICV)

PRESSURE INDEPENDENT CONTROL VALVE

PN 25

www.ecivalve.it

ECI EUROPEAN
CASTING
INDUSTRY

Installation of the pressure outlets and flow rate verification through the differential pressure gauge

The valve is equipped with connections for the pressure outlets to be installed with the system switched off and not under pressure.

Using the differential pressure gauge and its probes suitably housed in the pressure outlets, it is possible to measure the Δp of the valve (P1-P3) during normal operation.

⚠ WARNINGS:

Water leakage may occur through the pressure outlets during the insertion of the probes.
Wear protective clothing and goggles to prevent personal injury during pressure measurement.
Do not use lubricants on the probes to facilitate insertion into the outlets. If necessary, wet the probes with clean water.
Do not leave the probes in the pressure outlet longer than necessary, as this could cause leakage.

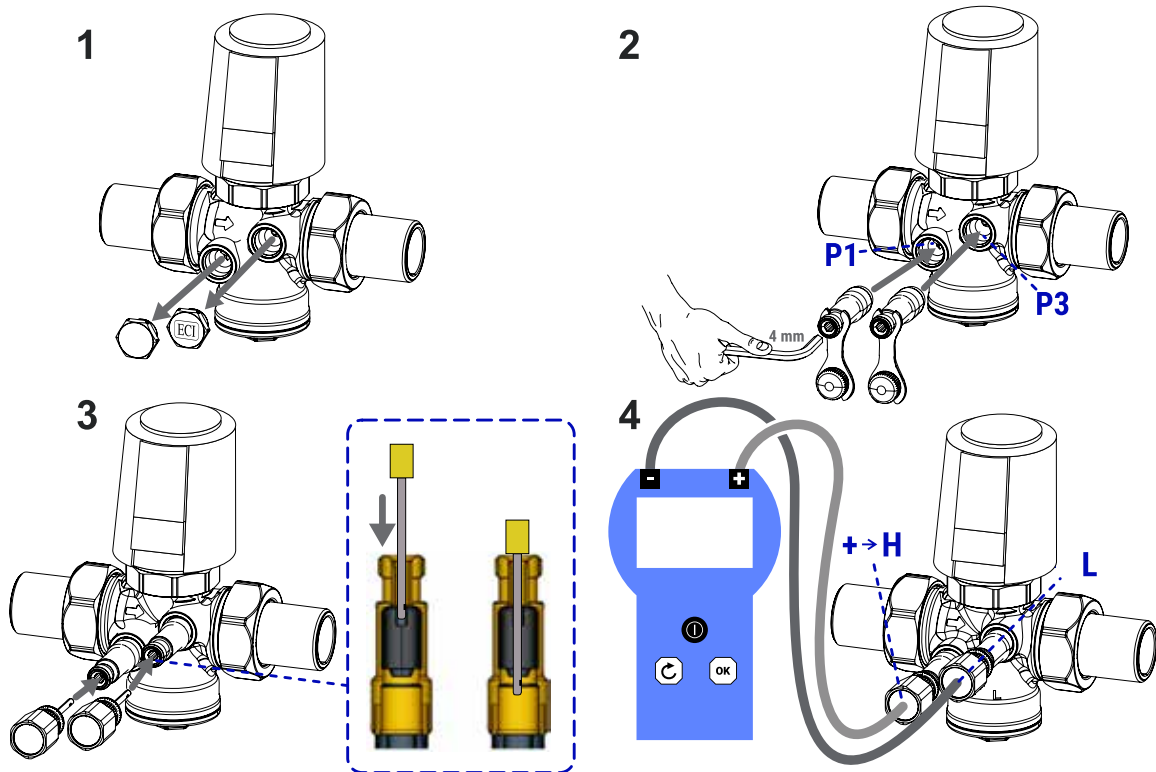

⚠ Safety Warning. Installation, commissioning and periodical maintenance of the product must be carried out by qualified operators in compliance with national regulations and/or local standards. A qualified installer must take all required measures, including use of Individual Protection Devices, for his and others' safety. An improper installation may damage people, animals or objects towards which ECI may not be held liable.

♻ Package Disposal. Carton boxes: paper recycling. Plastic bags and bubble wrap: plastic recycling.

♻ Product Disposal. Do not dispose of product as municipal waste at the end of its life cycle. Dispose of product at a special recycling platform managed by local authorities or at retailers providing this type of service.

ⓘ Additional information. For more information, go to the website www.ecivalve.it or contact us via email info@ecivalve.it. This document provides only general indications. The information included in this technical sheet do not exempt the user from strictly complying with the rules and good practice standards in force.

ECI EUROPEAN
CASTING
INDUSTRY

All data, descriptions and pictures contained in this leaflet may be subject to change without prior notice.

European Casting Industry Srl | Via Lazzaretto, 11 | 20124 Milan MI, Italia | P.Iva: 03228761205 | www.ecivalve.it | info@ecivalve.it





Valve Accessories

V1100/V1200

52

V1100/V1200

Thermo Electric actuator normally Closed ON/OFF
230V/24V for Pressure Independent Control Valve BS925

www.ecivalve.it

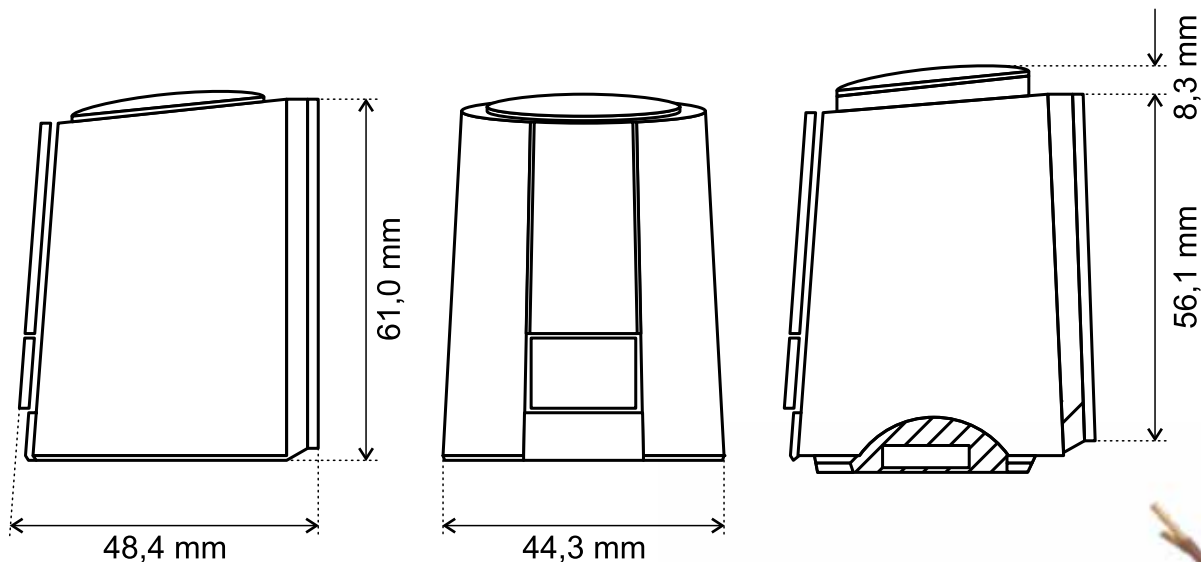

Dimensions (mm)

A	B	C	D	E	Weight(KGS)
48.4	61	44.3	59.1	8.3	0.108

Specifications:

V1100

- Supply Voltage: 230V AC \pm 10%, 50/60Hz
- Type: Thermal
- Power consumption: 1W
- Control Signal: ON/OFF
- Failsafe Function: Yes, normally closed
- End switch: No
- Operation time: Aprox 4 minutes
- Actuation force: 100N \pm 5%
- Room Temperature: 0°C to 60 °C
- Fluid Temperature: 0°C to 100°C
- Storage Temperature: -25°C to 60°C
- Cable: Fixed, 2 wires x 0.75mm² PVC, 1m standard M30x1.5mm connection
- Conforms to EN 60730 standard

V1200

- Supply Voltage: 24V AC/DC -10% +20% , 50/60Hz
- Type: Thermal
- Power consumption: 1W
- Control Signal: ON/OFF
- Failsafe Function: Yes, normally closed
- End switch: No
- Operation time: Aprox 4 minutes
- Actuation force: 100N \pm 5%
- Room Temperature: 0°C to 60 °C
- Fluid Temperature: 0°C to 100°C
- Storage Temperature: -25°C to 60°C
- Cable: Fixed, 2 wires x 0,75mm² PVC, 1m standard M30x1.5mm connection
- Conforms to EN 60730 standard



All data, descriptions and pictures contained in this leaflet may be subject to change without prior notice.

European Casting Industry Srl | Via Lazzaretto, 11 | 20124 Milan MI, Italia | P.Iva: 03228761205 | www.ecivalve.it | info@ecivalve.it

Certifications



All data, descriptions and pictures contained in this leaflet may be subject to change without prior notice.

European Casting Industry Srl | Via Lazzaretto, 11 | 20124 Milan MI, Italia | P.Iva: 03228761205 | www.ecivalve.it | info@ecivalve.it



Via Lazzaretto, 11
20124 Milan MI, Italy
Tel & Fax #: +39 0263793708
www.ecivalve.it

